

City of Lathrop, CA

Manthey Road Bridge Replacement Project PS12-04

WSP Project Number 12588A
Federal Aid Number BRLS-5456(016)
Bridge Number 29C0127

Project Report

September 2020



Recommended
for Approval By:

Michael King
Director of Public Works
City of Lathrop

Date



This project report has been prepared under the direction of the following registered civil engineer. The registered civil engineer attests to the technical information contained herein and the engineering data upon which recommendations, conclusions, and decisions are based.

James D. Gomez, PE

DATE



DRAFT

Table of Contents

1.0	Introduction.....	5
2.0	Recommendation	5
3.0	Background	5
3.1	Project History.....	5
3.2	Community Interaction	6
3.3	Existing Facility	6
4.0	Purpose and Need	8
4.1	Problem, Deficiencies, Justification.....	8
4.2	Regional and System Planning.....	9
4.3	Traffic.....	9
5.0	Alternatives	12
5.1	No Build Alternative	12
5.2	Preferred Alternative	12
5.2.1	Design Constraints	12
5.2.2	United States	13
5.2.3	Utility and Other Owner Involvement	13
5.2.4	Highway Planting and Lighting.....	13
5.2.5	Water Pollution Control.....	14
5.2.6	Non-motorized and Pedestrian Features	14
5.2.7	Architectural Elements.....	14
5.2.8	Railroad Involvement.....	14
5.2.9	Cost Estimate	15
5.2.10	Right of Way.....	15
5.3	Rejected Alternatives	16
5.3.1	Alternative 1.....	16
5.3.2	Alternative 2.....	16
6.0	Considerations Requiring Discussion	16
6.1	Hazardous Waste.....	16
6.2	Value Analysis	17
6.3	Environmental Compliance.....	17
6.4	Air Quality Conformity	17
6.5	Title VI Considerations	17
7.0	Other Considerations as Appropriate.....	18

7.1	Public Outreach Meeting.....	18
7.2	Permits.....	18
7.3	Cooperative Agreements	18
7.4	Consultation with Tribal Government.....	18
7.5	Stage Construction	18
8.0	Funding/Programming	19
9.0	Schedule.....	19
10.0	Risks.....	19
11.0	Project Reviews	19
12.0	Project Personnel	19
13.0	ATTACHMENTS.....	20

List of Figures

Figure 4-1.	Intersection of Stewart Road and Golden Valley Parkway.....	11
-------------	---	----

List of Tables

Table 3-1.	Existing Manthey Road Bridge Characteristics	7
Table 3-2.	Existing Manthey Road Bridge Span Configuration.....	7
Table 3-3.	Existing Manthey Road Bridge Bent Configuration	7
Table 4-1.	Intersection Analysis – Design Year 2040	10
Table 5-1.	Proposed Project Preliminary Cost Estimate Summary	15
Table 7-1.	List of Permits	18
Table 9-1.	Project Milestone Schedule	19

1.0 Introduction

The City of Lathrop (City) is proposing to replace the Manthey Road Bridge (No. 29C-0127) across the San Joaquin River approximately 0.3 miles northeast of Stewart Road. Manthey Road is a two-lane frontage road that runs southwest–northeast, parallel to Interstate 5 (I-5), with a posted speed limit of 40 mph. It is a local and regional route that crosses the San Joaquin River northwest of I-5, providing connectivity to the River Islands and Mossdale developments, which are the City’s two largest development areas. San Joaquin River at this location is considered a navigable river under jurisdiction of the Eleventh United States Coast Guard District. All the existing movable bridges within the project area are no longer in operation and have been locked in closed position.

The proposed bridge replacement is needed to provide safety, operational improvements, and multimodal enhancements that will accommodate future traffic demands. Preliminary engineering studies and the environmental documentation process have been completed for Alternative 3, the preferred alternative.

This project will be funded by the Federal Highway Bridge Program.

2.0 Recommendation

It is recommended that Alternative 3 be approved to advance the project to final design, preparation of construction documents and right-of-way acquisition.

3.0 Background

3.1 Project History

The existing Manthey Road Bridge (Bridge Number 29C0127) is a two-lane crossing over the San Joaquin River in the City of Lathrop. Built in 1926, this bridge was determined to be both “Structurally Deficient” and “Functionally Obsolete” by the California Department of Transportation (Caltrans) in September 2012. The existing bridge is a Pratt camelback through steel truss with a Bascule lift approach on the north end. This type of bridge is typically not suitable for widening. The City is therefore proposing a new San Joaquin River Crossing under the Federal Highway Bridge Program (Federal Project No. BRLS-5456[016]).

To assure fiscal responsibility, a Feasibility Study, directed by Caltrans, comparing rehabilitation to replacement was completed in August 2015, concluding that the bridge should be replaced.

In support of Preliminary Engineering and Environmental Services, the City approved the Basis of Design Memorandum (BDM) in May 2014. The BDM establishes and documents bridge design standards and criteria for this project. Each bridge alignment option was developed in keeping with the design criteria established in the BDM.

Three replacement alternatives were initially considered:

- Alternative 1 - Demolishing the bridge and replacing it at the existing bridge location.
- Alternative 2 - Replacing the bridge at a location between the existing Union Pacific Railroad (UPRR) Bridge and the existing Bicycle/Pedestrian Bridge.

- Alternative 3 - Replacing the bridge at a location downstream of the UPRR Bridge along the designated future Golden Valley Parkway (GVP) extension as identified in the City's General Plan. This alignment would connect Stewart Road on the west side of the river to Golden Valley Parkway on the east at the intersection with Brookhurst Blvd.

A Constraints Analysis evaluated each alternative pertaining to geometrics, traffic, utilities, right-of-way, and both natural and built environments. Completed in July 2014, the analysis found that Alternative 2 would have similar impacts to Alternate 3 with an additional element of impact to Mossdale County Park which is a Section 4(f) resource. Subsequently, Alternative 2 was eliminated.

Alternative 1 was later withdrawn after technical studies were completed because it did not support the City's long-term circulation plan and local communities concern with truck traffic along this alignment.

3.2 Community Interaction

On November 12, 2014, the City held a Public Information Meeting at the Lathrop Senior Center. City and Consultant staff presented an overview of the project, the environmental process, the current status of the project, and explained how residents could submit their questions and comments. The majority of the public expressed support for the project, with questions and concerns regarding impacts to traffic, noise, and air quality during construction. Written comments received included:

1. Two different types of hawks reside on my street along with white skunk. I am concerned about effects on wildlife.
2. Increased traffic on South Manthey to school on River Island. Unsafe driving practices and speed concerns. School bus has to turn around on roadway at 18666 S. Manthey.
3. Preference: Option #3 bridge. Limit traffic or no traffic over the existing bridge.

Responses to all comments received to date have been summarized in the technical studies.

In addition to the Public Information Meeting, progress reports were made by City staff at City Council meetings throughout the environmental compliance process. No additional questions or concerns were noted from the City Council meetings.

3.3 Existing Facility

The Manthey Road Bridge is a two-lane crossing over the San Joaquin River in the City of Lathrop. It extends from the City of Stockton south to the City of Lathrop, along the west side of I-5 in San Joaquin County. In Lathrop, Manthey Road has been removed between Louise Avenue and Towne Centre Drive. From Towne Centre Drive, the road continues south and crosses the San Joaquin River, providing access to the River Islands and Mossdale developments, which are the City's two largest development areas. Built in 1926, the bridge is a Pratt camelback through steel truss with a Bascule lift approach on the north end. The bridge has a pedestrian walkway on the southeast side outside of the main truss; however, this walkway is currently closed due to its poor and unsafe condition. Additional characteristics of the bridge are listed below in Tables 3-1 to 3-3:

Table 3-1. Existing Manthey Road Bridge Characteristics

Year Built	1926
Total Length	536'-7"
Total Width	33'-5"
Roadway Width	24'-3"
Sidewalk Width	5'-11" (sidewalk currently closed due to decayed condition)
No. of Lanes	2
Minimum Vertical Clearance	15'-3"
Functional Classification	Rural Major Collector
Channel Description	Earth, sand and brush lined channel with rock protected slope at Abutment 11

Table 3-2. Existing Manthey Road Bridge Span Configuration

Span	1	2 - 5	6	7	8 & 9	10
Length	25'-6"	26'-6"	201'-7"	125'-0"	26'-6"	25'-6"
Structure Type	Reinforced Concrete "T" Girders (4)		Through Pin Connected Steel Curved Chord Truss	Single Bascule**	Reinforced Concrete "T" Girders (4)	
Deck	Reinforced Concrete			Open Grate	Reinforced Concrete	

**The bascule is no longer operational. The concrete counterweight and other operable features were removed in 1972.

Table 3-3. Existing Manthey Road Bridge Bent Configuration

Bent	Abutment 1	Bents 2 - 5	Bent 6 & 7	Bent 8	Bent 9 & 10	Abutment 11
Type	Reinforced Concrete Short Seat	Reinforced Concrete 4-Column Rigid Frame	Reinforced Concrete Solid Wall Pier	Reinforced Concrete 2-Column Rigid Frame	Reinforced Concrete 4-Column Rigid Frame	Reinforced Concrete Short Seat
Foundation Type	Timber Piles	Reinforced Concrete Piles	Timber Piles		Reinforced Concrete Piles	Timber Piles

Listed below are the existing Manthey Road Bridge deficiencies found in the 2012 Caltrans Bridge Inspection Report:

- Concrete spalls with exposed rebar on deck in span 6
- Transverse cracks, full width, greater than 1/16 inch wide and spaced up to three feet on center in span 6
- Timber walkway is decayed and in poor condition
- Broken patch of steel deck in span 7
- Loose and missing angle irons at joints
- Concrete spalls with exposed rebar on concrete barrier rails in multiple spans
- A 4-foot section of barrier rail missing on left side of abutment 11
- Soil and debris have filled the scupper drains on the deck
- Concrete spall with exposed rebar on girder 3 in span 1
- Hairline to 1/32 inch wide rusted transverse soffit cracks in spans 1, 2, 3, 4, 5, 6 and 9

- Concrete spalls with exposed rebar on left overhang near abutment 11
- Missing rivets on gusset plates connected to the lower strut of the portal bracing
- Erosion gully along abutment 1 face exposing abutment piles
- Vertical 1/8 inch to 1/4 inch cracks on left sides of the bent caps at bents 2 and 3 with incipient spalling
- Multiple major concrete spalls with exposed rebar on the right and left faces of column 4 at bent 5
- Concrete spall with exposed rebar on column 1 at bent 5
- Concrete spalls with exposed rebar along the top of the concrete bent cap at bent 5
- Two full height cracks up to 1/8 inch wide on both sides of the pier wall at bent 6
- Full height crack up to 1/2 inch wide on pier wall at bent 7
- Multiple 1/4-inch-wide vertical cracks on all sides of columns at bent 8
- Three vertical cracks up to 1/8 inch wide on concrete strut at bent 8
- Settlement of gabion mattresses exposing piles at abutment 11
- Multiple trees and vegetation growing under span 6 and between columns 1 and 2 at bents 3 and 5
- Paint is faded and chalky; rust, peeling and pitting throughout
- Top of footing at pier 7 is exposed

4.0 Purpose and Need

4.1 Problem, Deficiencies, Justification

Improvements are needed to provide safe travel by all modes of transportation: automobile, transit, bicycle, and pedestrian. The need for the proposed project is supported by the transportation problems identified below:

- **Safety:** The bridge received a 7.1 sufficiency rating by Caltrans and was determined to be “Structurally Deficient” and “Functionally Obsolete” based on the September 2012 Caltrans Bridge Inspection Report. The current bridge does not meet standard lane and shoulder widths, and the existing superstructure does not allow widening.
- **Consistency with circulation patterns in adopted plans:** The current bridge on Manthey Road is a major crossing of the San Joaquin River serving the City of Lathrop. Prior to approval of the 2002 West Lathrop Specific Plan (WLSP) and the beginning of construction in Mossdale Village in 2004, the WLSP area was almost entirely agricultural. The WLSP allows for development of three mixed-use projects (Mossdale Village, River Islands, and Southeast Stewart Tract). Since approving the WLSP, the circulation patterns have changed and communities have expanded southward and westward, requiring a better connection across the San Joaquin River. When considering a replacement structure, the City must take into account current and future circulation patterns based on adopted plans.

- Multimodal enhancements: The existing bridge width is not adequate to accommodate bike lanes or shoulders. Currently, bicycle traffic must use the adjacent pedestrian bridge. The City's General Plan and the West Lathrop Specific Plan identify multimodal enhancements and include Class II bike lanes. The new bridge will accommodate Class II bike lanes, encouraging nonmotorized traffic over a safe river crossing.

Based on the needs identified above and as defined in the environmental document, the purpose of the project is as follows:

- Purpose 1: To improve safety related to the bridge and more generally within the project area.
- Purpose 2: To provide circulation to current and future residential areas and surrounding development consistent with adopted plans.
- Purpose 3: Improve multimodal transportation in the City of Lathrop across the San Joaquin River

The proposed project would function and address the purpose and need identified above without additional improvements. The project would connect two roadway sections and provide a river crossing. No other project would be required for the project to function adequately and meet the project purpose and need. Therefore, the project has independent utility. The project would also connect logical termini. The proposed project would extend Golden Valley Parkway from its current terminus at Brookhurst Boulevard in the north, to Stewart Road in the River Islands development west of the river.

4.2 Regional and System Planning

The Manthey Road bridge serves local traffic crossing the San Joaquin River connecting the developed part of the City of Lathrop to the River Islands Development area and the farmland west of the San Joaquin River. The project will provide multi-modal enhancements consistent with the City's General Plan and the West Lathrop Specific Plan.

4.3 Traffic

The Final Traffic Operations Analysis Report (TOAR) for the Manthey Road Bridge Replacement Project was approved September 19, 2014. The project study area extends along Manthey Road from Stewart Road to the south and Brookhurst Boulevard to the north. The primary roads include Manthey Road, Golden Valley Parkway, Brookhurst Boulevard, Inland Passage Way, Sadler Oak, Queirolo Road, and Stewart Road. Manthey Road generally runs parallel to I-5, south of Sadler Oak, and residential properties are located on both sides of Manthey Road. Six intersections and three roadway segments were selected to be analyzed for the transportation and traffic study. The following table is the Intersection Analysis for Design Year 2040:

Table 4-1. Intersection Analysis – Design Year 2040

Intersection	Control¹	No-Build Alternative Morning Peak Hours Level of Service	No-Build Alternative Evening Peak Hour Level of Service	Build Alternative Morning Peak Hours Level of Service	Build Alternative Evening Peak Hour Level of Service
Northbound Left Turn Manthey Road / Stewart Road	Uncontrolled	A	A	A	A
Northbound Through Manthey Road / Stewart Road	Uncontrolled	A	A	A	A
Southbound Through Manthey Road / Stewart Road	Uncontrolled	A	A	–	–
Southbound Right Turn Manthey Road / Stewart Road	Uncontrolled	A	A	–	–
Eastbound Left Turn Manthey Road / Stewart Road	Uncontrolled	A	A	–	–
Eastbound Right Turn Manthey Road / Stewart Road	Uncontrolled	A	A	–	–
Northbound Left Turn Manthey Road / Mossdale County Park Access	Uncontrolled	A	A	–	–
Northbound Through Manthey Road / Mossdale County Park Access	Uncontrolled	A	A	–	–
Southbound Through Manthey Road / Mossdale County Park Access	Uncontrolled	A	A	–	–
Southbound Right Turn Manthey Road / Mossdale County Park Access	Uncontrolled	A	A	A	A
Eastbound Left Turn Manthey Road / Mossdale County Park Access	Uncontrolled	A	A	A	A
Eastbound Right Turn Manthey Road / Mossdale County Park Access	Uncontrolled	A	A	–	–
Northbound Left Turn Manthey Road / Brookhurst Boulevard	Side-Street Stop	A	A	A	A
Northbound Through Manthey Road / Brookhurst Boulevard	Side-Street Stop	A	A	A	A
Southbound Through Manthey Road / Brookhurst Boulevard	Side-Street Stop	A	A	A	A
Southbound Right Turn Manthey Road / Brookhurst Boulevard	Side-Street Stop	A	A	A	A
Eastbound Left Turn Manthey Road / Brookhurst Boulevard	Side-Street Stop	A	A	A	A
Eastbound Right Turn Manthey Road / Brookhurst Boulevard	Side-Street Stop	A	A	A	A
Golden Valley Parkway / Stewart Road	Signalized	–	–	C	C
Golden Valley Parkway / Sadler Oak Drive	Signalized	–	–	B	B
Golden Valley Parkway / Brookhurst Boulevard	Signalized	–	–	B	C

As a bridge replacement project with no capacity increase, traffic patterns would remain the same in general. If parallel facilities are constructed, however; the traffic would be reduced.

An existing agreement between the City of Lathrop and Caltrans restricts access from River Islands to the Manthey/I205 interchange. In order to comply with the terms of the existing agreement, this project will prohibit the following seven movements at the new Golden Valley Parkway / Stewart Road intersection:

1. Northbound Stewart left-turn onto Golden Valley Parkway
2. Northbound Stewart through movement
3. Southbound Stewart left-turn movement onto Golden Valley Parkway
4. Southbound Stewart through
5. Westbound Golden Valley Parkway right-turn onto Stewart Road
6. Eastbound Golden Valley Parkway right-turn onto Stewart Road
7. Eastbound Golden Valley Parkway left-turn onto Stewart Road

Arrows shown below in Figure 1-5 indicate allowed vehicle movements. All other movements will be prohibited.

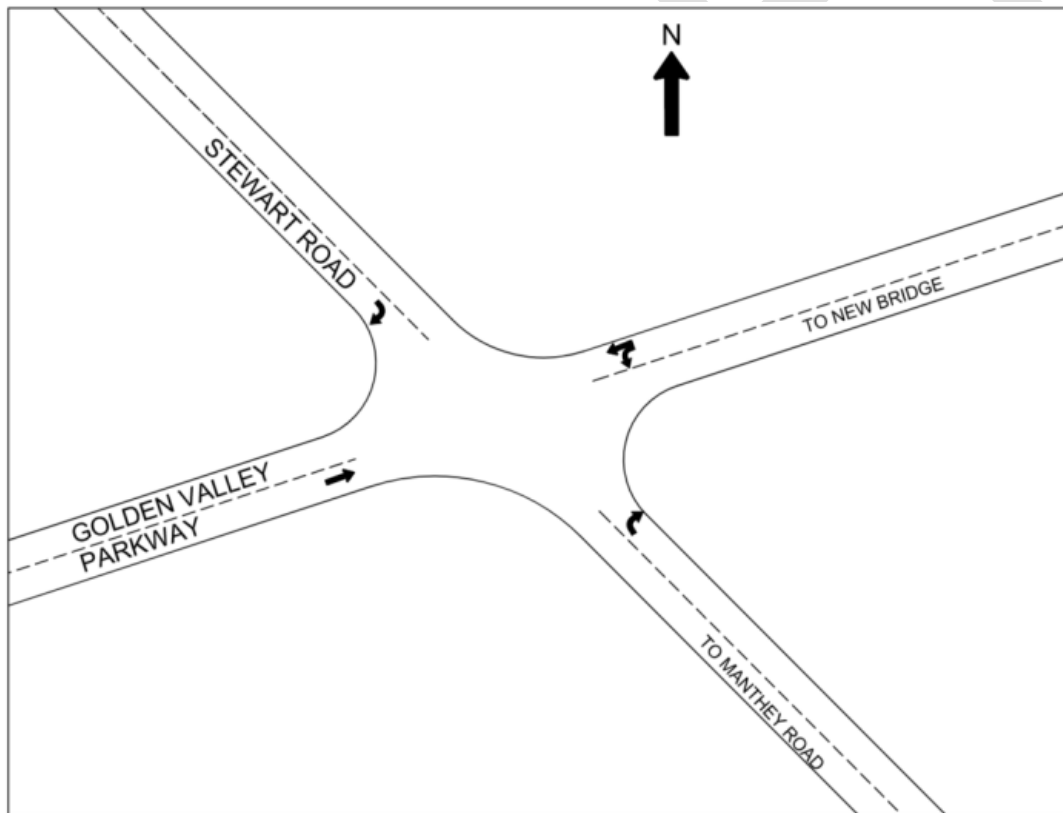

Figure 4-1. Intersection of Stewart Road and Golden Valley Parkway

Under Existing Conditions, all study intersections operate in LOS A for all turning movements for both the AM and PM peak hours. All roadway segments operate in acceptable conditions (LOS C

or better). And with these turning prohibitions, all study intersections and roadway segments are projected to operate at acceptable service levels under 2040 Plus Proposed project Conditions.

5.0 Alternatives

5.1 No Build Alternative

Under the No Build Alternative, the existing Manthey Road Bridge would remain in its current location, and no facilities would be constructed to satisfy the purpose and need identified above. The existing Manthey Road bridge would not be rehabilitated and would continue to be both structurally deficient and functionally obsolete. It would be poorly situated to serve the new communities in the City of Lathrop's adopted plans, and would not have sidewalks, bike lanes, or shoulders. An additional concern would be the continued deterioration of the existing bridge.

5.2 Preferred Alternative

Under the Build Alternative (Proposed project), the City would replace the existing bridge with a new bridge downstream of the existing railroad bridge and demolish the existing bridge (Figure 3). The preliminary alignment for this alternative follows the proposed Golden Valley Parkway alignment across the San Joaquin River, in accordance with the West Lathrop Specific Plan (WLSP) connecting Brookhurst Road and Stewart Road, east and west of the river respectively.

The proposed project would construct a 1-mile-long segment of Golden Valley Parkway along the alignment outlined in the WLSP. Though eventually planned as a four-lane arterial, the road constructed under this project would have two 12-foot lanes, with 8-foot shoulders and 5-foot sidewalks located within one-half of the proposed right-of-way that has been identified for the parkway. The new roadway approach would extend from Brookhurst Boulevard in the north heading southward, turn to the west, cross the San Joaquin River on the new bridge alignment, and connect to Stewart Road in the River Islands development west of the river. Intersection improvements would be made at Brookhurst Boulevard and Saddler Oak. The bridge would conform to existing ground level at Stewart Road. See Attachment C of this report for proposed project roadway typical section and plan/profile drawings.

A bridge Type Selection Report was prepared by WSP. The TSR, dated April 2020, recommends a single-frame replacement bridge. The new bridge would measure approximately 532 feet long by 53 feet wide. The new bridge will accommodate two 12-foot traffic lanes; two 8-foot shoulders; two 5-foot, 6-inch sidewalks; and concrete barriers and tubular handrails. The bridge would be supported by three sets of two piers supported by cast-in-steel-shell piles in the river and abutments on both ends supported by cast-in-drilled-hole piles. The bridge superstructure would be precast, prestressed concrete bulb-tee girders with a cast-in-place concrete deck or a cast-in-place, post-tensioned concrete box girder. See Attachment D of this report for a General Plan of the preferred bridge alternative recommended in the TSR.

5.2.1 Design Constraints

Since the preparation of the Constraint Analysis in 2014, refinements were made through additional coordination during the environmental compliance phase. Specifically, with respect to bridge soffit elevation. The soffit of the proposed bridge must be at least 3 feet above the 200-year water surface elevation of the San Joaquin River per Central Valley Flood Protection Board

(CVFPB) requirements; U.S. Army Corps of Engineers requires 3 feet above the top of levee; and RD 17 will require 15 feet of vertical clearance under Manthey Road for maintenance access. RD 2107 on the River Islands side of the San Joaquin River does not have any clearance requirement.

At the new bridge location, the existing top of levee is higher than the 200-year water surface elevation. Therefore, the profile grade of Golden Valley Parkway will be set at an elevation that provides a minimum of 3 feet vertical clearance above the levees. To minimize the bridge and associated roadway approach heights, a 15-foot by 15 foot culvert crossing is proposed on the land-side of the east levee (Mossdale side).

5.2.2 United States

The San Joaquin River is considered a navigable waterway of the United States for bridge administration purposes. A Bridge Permit will be required from the US Coast Guard (application to be submitted during the Design Phase). In a letter dated October 3, 2016, Mr. David H. Sulouff, USCG Bridge Section Chief, indicated that the following navigational clearances must be provided:

- Vertical Clearance: A minimum of 29 feet at the lowest hittable portion of the bridge at Mean High Water.
- Horizontal Clearance: A minimum of 118 feet, pier face to pier face, or fender to fender, normal to the axis of the channel.

5.2.3 Utility and Other Owner Involvement

The proposed project will extend the existing Golden Valley Parkway through existing farmland. There are no existing utilities within the farmland longitudinally along the corridor except at the tie-in points of the alignment. There may be minor modifications to existing utilities at the connection points including modifications to manholes, drainage structures, water valves, and other appurtenances. Relocation of one power pole on the Mossdale Landing side of the San Joaquin River may also be required.

Utility coordination efforts to date have consisted of requesting record drawings (A letters) to utility companies only. Final design activities will include coordination with utility companies. Coordination activities will include, at a minimum, utility B and C letters. It is anticipated that utility companies will want to place utilities on the new bridge. Regardless if utilities will be placed in the new bridge by opening day, the new bridge design should provide utility openings to accommodate future needs.

5.2.4 Highway Planting and Lighting

The existing built sections of Golden Valley Parkway have landscaping and lighting in the median. New landscaping should be consistent with the built sections of GVP and the Landscape Architecture Standards for the Golden Valley Parkway identified within the City's Urban Design Concept Plans. Along the north shoulder, only smaller shrubs, grasses, vines and groundcover should be considered to minimize throw away when the road is widened in the future. Landscaping along bermed bridge approaches and Golden Valley Parkway will improve the visual quality of the roadway corridor by improving corridor aesthetics and helping to reduce the apparent scale of the berms and width of the roadway corridor for the Preferred Alternative. This landscaping also will serve as a buffer and screen against nuisance lighting resulting from oncoming vehicle

headlights and roadway lighting and help to prevent or greatly reduce nuisance lighting from affecting nearby sensitive viewers.

The City's municipal code promotes the use of street trees to reduce glare (Section 12.16.010). In addition, the street lighting standards of the Urban Design Concept Plans dictate that shielding devices be used to prevent light trespass into adjacent residential units and that the spacing and brightness of lights shall meet City, Pacific Gas and Electric Company, and State of California standards for illumination and safety. In addition to these measures, all lighting is to cause minimum impact on the surrounding environment and will use downcast, cut-off type fixtures that are shielded, and direct the light only toward surfaces requiring illumination. Lights must be installed at the lowest allowable height and cast low-angle illumination while minimizing incidental light spill onto adjacent properties or open spaces, including the river, or backscatter into the nighttime sky. Lights will provide warmer color temperatures (i.e., no greater than 3500 Kelvin), with the minimum lumens feasible for security and safety to reduce the potential for creating harsh, nuisance-lighting conditions. Light fixtures will have non-glare finishes that will not cause reflective daytime glare. Design measures used to reduce light pollution will incorporate the technologies available at the time of project design to allow for the highest potential reduction in light pollution.

5.2.5 Water Pollution Control

A Water Quality Assessment Report was prepared for the proposed project and approved by the City in September 2018. Construction activities for the proposed project must comply with the applicable requirements of the General Construction Activity Stormwater permit. The Central Valley Regional Water Quality Control Board (RWQCB) must be consulted to obtain information regarding the National Pollutant Discharge Elimination System (NPDES) permit requirements. The proposed project will increase the amount of impervious area in the project vicinity.

During construction, a Storm Water Pollution Prevention Plan (SWPPP) will be developed and implemented for the proposed project.

5.2.6 Non-motorized and Pedestrian Features

Since the timing of the future roadway widening is unknown at this time, the proposed project will include Class II bike lanes and sidewalks along both sides of Golden Valley Parkway. When Golden Valley Parkway is widened to four lanes in the future, the sidewalk and Class II bike lane on the northwest side of Golden Valley Parkway will be removed and new sidewalk and Class II bike lane will be constructed along the northwest side of the widened roadway.

5.2.7 Architectural Elements

The proposed project will follow City's design standard and current parkway aesthetic treatments. The proposed bridge will have pedestrian/ bike railing. During the final design of the project, architectural features will be further developed based on input provided by the City.

5.2.8 Railroad Involvement

This alternative does not affect the railroad improvements or the railroad right-of-way.

5.2.9 Cost Estimate

The replacement of the Manthey Road bridge will be funded in large part by the federal Highway Bridge Program (HBP). Due to the nature of the funding type, Caltrans has limited the HBP participation for this project to the removal of the existing bridge, construction of the new bridge and 200' of roadway approach (including modifications to Manthey Road/Stewart Road intersection). The remainder of the roadway approach will be non-participating costs funded locally by the City.

The roadway, structure, right of way, and utility costs for the proposed project are summarized in Table 5-1 below.

Table 5-1. Proposed Project Preliminary Cost Estimate Summary

Description	Participating Cost	Non-Participating Cost	Total Cost
Roadway Items	\$3,331,000	\$8,064,000	\$11,394,000
Structure Items	\$12,440,000	\$0	\$12,440,000
R/W	\$510,000	\$1,130,000	\$1,640,000
Utilities	\$0	\$0	\$0
Biological Mitigation	\$424,000	\$0	\$424,000
Total	\$16,705,000	\$9,194,000	\$25,900,000

The full preliminary cost estimate can be found in Attachment E of this report.

5.2.10 Right of Way

Although the City's West Lathrop Specific Plan (2003) proposed a minimum right-of-way width of 150' for Golden Valley Parkway in Stewart Tract and up to 156' in River Islands, the most recent City planning document, Mossdale Landing South-Urban Design Concept (amended February 2009), a narrower 116' cross section for Unit 2 covers the project's extension from Brookhurst Boulevard to the San Joaquin River.

Based on the 5' offset from proposed toes of fill at 4:1 fill slope or the minimum 116' width per the Mossdale Landing South-Urban Design, the project would require partial right-of-way acquisition from 11 privately owned properties. Temporary acquisitions would consist of approximately 0.27 acre from APN 241-020-61, 0.09 acre from APN 241-020-08, 0.53 acre from APN 241-020-63, 1.9 acres from APN 241-020-68, 0.22 acre from APN 241-020-67, 0.85 acre from APN 241-020-68, 0.11 acre from APN 213-310-06, and 3.23 acres from APN 213-310-15. Permanent acquisition would consist of approximately 0.04 acre from APN 191-190-15, 0.03 acre from APN 241-020-08, 3.84 acres from APN 241-020-63, 1.68 acres from APN 241-020-68, 0.48 acre from APN 241-020-68, 0.33 acres from APN 213-310-06, and 1.17 acres from APN 213-310-15, while permanent easements from RD 17 and RD 2062 would consist of 0.12 acre from APN 241-020-67 (RD 17) and 0.33 acre from APN 213-310-06 (RD 2062). This would result in a total permanent right-of-way acquisition of 7.57 acres, temporary easements of 7.20 acres, and permanent easements of 0.45 acre.

The proposed project will not have a permanent impact to Caltrans right-of-way. However, a temporary encroachment permit may provide staging opportunities during removal of the existing bridge.

A Right of Way Impact Exhibit can be found in Attachment F of this report.

5.3 Rejected Alternatives

5.3.1 *Alternative 1*

Under Alternative 1, the City would demolish the existing bridge and replace it with a new bridge in the same location. The new bridge would measure approximately 538 feet long by 34 feet, 10 inches wide and would accommodate two 12-foot-wide traffic lanes, two 4-foot-wide shoulders, and concrete traffic barriers with tubular railings. The bridge would be supported by four piers supported by cast-in-steel shell piles in the river and an abutment on either side supported by cast-in-drilled-hole piles. To meet U. S. Army Corps of Engineers (USACE) vertical clearance requirements, the new bridge would be slightly higher (approximately 8 feet) than the existing bridge. A combination of fill slopes and retaining walls would be used to retain the higher approach roadway.

Within the project limits, the approach roadway on either side of the bridge would be widened to conform to the bridge. The Manthey Road/Stewart Road T-intersection west of the bridge would be modified to accommodate the new bridge and roadway. The driveway that provides access to Mossdale County Park would have to be reconstructed due to the new grade of Manthey Road.

Alternative 1 was subsequently removed from consideration by the City's project development team because it did not meet the project purpose and need as well, or for as long as the proposed project. Additionally, local residents were concerned with truck traffic on existing Manthey Road, favoring Alternative 3 instead.

5.3.2 *Alternative 2*

Under Alternative 2, the Manthey Road Bridge would be demolished and replaced on another alignment approximately 300 feet north or downstream of the existing bridge, and south or upstream of the Union Pacific Railroad (UPRR) Bridge. This Alternative would require realignment of a portion of Manthey Road from its existing alignment. The realignment would begin from the north side of the railroad underpass to the intersection of Stewart Road. This Alternative would also require the reconstruction of the railroad underpass and realignment of the road through Mossdale Park. Construction of this alternative would require temporary realignment of the UPRR tracks while the undercrossing was widened.

This alternative was withdrawn from consideration because other alternatives were feasible and functioned at least as well, and did not result in conflicts with the UPRR, or the placement of the realigned road within a park (a Section 4(f) resource).

6.0 Considerations Requiring Discussion

6.1 Hazardous Waste

A Phase I Environmental Site Assessment was performed for the proposed project site. Within the limits of the preferred alternative, one potential source of hazardous material may exist (location 5 of the Initial Site Assessment). Due to historical agricultural use of the property, farm debris and potential agricultural chemical storage and/or mixing area, soil sampling in select areas is

recommended. Additionally, sampling for aerially deposited lead and asbestos in the vicinity of the existing bridge is recommended towards developing proper handling and disposal provisions.

6.2 Value Analysis

The construction cost for this project doesn't reach the current federal threshold of \$50 million (\$40 million for bridges). Therefore, no formal Value Analysis was performed for this project.

6.3 Environmental Compliance

The final ISMND/EA has been bound separately, but the approval pages are included in Attachment A.

The environmental issues identified in the ISMND/EA include cultural sensitivities, farmland conversion, riparian and tree removal, visual impacts, pile driving noise, temporary and permanent loss of habitat for biological resources. Proposed mitigation measures are included in Appendix D, "Avoidance, Minimization, and Mitigation Measures," of the ISMND/EA.

Extended Phase I cultural study indicated that while no archeological resources meeting the criteria for historic properties were located within the Area of Direct Impact, there are areas that are sensitive for buried resources that may contain intact deposits. Disturbance or destruction of archaeological deposits that are eligible for listing in the National Register of Historic Places resulting from ground-disturbing activities during construction would be an adverse effect. To reduce the severity of potential impacts, monitoring in sensitive areas will be required, and a Post-Review Discovery and Monitoring Plan is being prepared to guide monitoring and discovery response during construction.

6.4 Air Quality Conformity

The project would retain the same or nearly the same alignment for the purposes of air quality analysis and would not increase capacity of motorized vehicles.

This project (ID SJ07-3014) is included in the regional emissions analysis conducted by the San Joaquin Council of Governments (SJCOG) for the conforming *2018 Regional Transportation Plan/Sustainable Communities Strategy* (RTP/SCS) (San Joaquin Council of Governments 2018) and *2019 Federal Transportation Improvement Program* (FTIP).¹ The project's design concept and scope have not changed significantly from what was analyzed in the regional emission analysis. This analysis found that the plan, which takes into account regionally significant projects and financial constraint, will conform to the SIPs for attaining and maintaining the National Ambient Air Quality Standards (NAAQS) as provided in Section 176(c) of the Clean Air Act. FHWA determined that the RTP/SCS conforms to the SIP on December 3, 2018.

6.5 Title VI Considerations

Throughout the project area, provisions have been made to incorporate low mobility and minority groups. A Class II bike lane and sidewalks are proposed along both sides of the Golden Valley

¹ Note that SJ07-3014 covers the new Golden Valley Parkway (two-lane configuration). The bridge replacement is exempt from regional conformity and is included in the RTP/SCS as part of the highway bridge program grouped listing.

Parkway corridor. All sidewalks within the project are compliant with the most recent American with Disabilities Act (ADA) standards and provide truncated domes for individuals with visual handicaps.

7.0 Other Considerations as Appropriate

7.1 Public Outreach Meeting

A public outreach meeting was held on November 12, 2014. The majority of the comments received were in support of the project.

7.2 Permits

The following permits are required for this project:

Table 7-1. List of Permits

Agency	Permit/Approval	Status
Regional Water Quality Control Boards	Clean Water Act, Section 401 Water Quality Certification	Application to be submitted during Design Phase
United States Army Corps of Engineers	Clean Water Act, Section 404 Nationwide Permit	Application to be submitted during Design Phase
United States Army Corps of Engineers	Title 33, US Code, Section 408 Permit for alteration to infrastructure (levee)	Application to be submitted during Design Phase
California Department of Fish and Wildlife	CDFG code, Section 1602, Lake and Streambed Alteration Agreement	Application to be submitted during Design Phase
Central Valley Flood Protection Board	Encroachment Permit	Application to be submitted during Design Phase
United States Fish and Wildlife Service/ National Marine Fisheries Service	Endangered Species Act, Section 7: Biological Opinion	Biological Assessment was approved by USFWS on XXXX 2020 and by NMFS on August 31, 2020
California State Historic Preservation Officer	Section 106 Concurrence	In process
State Lands Commission	Use Permit	Application to be submitted during Design Phase
United States Coast Guard	Bridge Permit	Application to be submitted during Design Phase
Reclamation Districts 17 and 2062	Approval	Approval request to be submitted during Design Phase

7.3 Cooperative Agreements

No cooperative agreement is required with any governmental agency for this project.

7.4 Consultation with Tribal Government

Consultation with triable governments has been conducted for the project as part of compliance with AB52. In addition, tribal representative was present during the cultural field investigation and provided input to the project team.

7.5 Stage Construction

The existing Manthey Road and Manthey Road Bridge would remain in operation during construction of the new bridge and the newly realigned Manthey Road. No temporary detours will be required for this alignment Alternative. Existing bridge will be removed after completion of the project.

8.0 Funding/Programming

The project will be funded under the Federal Highway Bridge Program (Federal Project No. BRLS-5456[016]). The funding was authorized for the above project on March 29, 2013. The federal participation for this project is 88.5% of the participating items of construction. The current federal participation limits are set at bridge plus about 200' the approach roadways, plus the demolition of the existing bridge.

9.0 Schedule

Table 9-1. Project Milestone Schedule

Project Milestone	Date
Complete PA & ED	December 2020
Complete PS&E	March 2022
Right of Way Certification	March 2022
Ready to List	May 2022
Approve Contract	August 2022
Construction Contract Complete	February 2025

10.0 Risks

A Level 2 Risk Register and risk analysis were completed for the project. The potential project risks were identified through various discussions at the PDT meetings and stakeholders' input. A copy of the current Risk Register is included in Attachment G.

11.0 Project Reviews

This Project Report has been reviewed by the City of Lathrop. All comments have been incorporated or satisfactorily resolved.

12.0 Project Personnel

The following individuals may be contacted for information pertaining to this Project Report:

CITY OF LATHROP

- Michael King - (209) 941-7454
Project Manager

ISL/City of Lathrop

- Ivy Lane – (209) 584-4537
Project Oversight

WSP – Bridge & Roadway Design

- Ali Seyedmadani – (916) 567-2524
Project Manager

ICF International Inc. - Environmental

- Shahira Ashkar – (916) 752-0935
Environmental Lead

Crawford & Associates - Geotechnical

- Ben Crawford – (916) 455-4225
Geotechnical Lead

WRECO – Drainage & Bridge Hydraulics

- Han-Bin Liang – (925) 941-0017
Drainage Lead

Fehr & Peers - Traffic

- Fred Choa – (916) 262-7392
Traffic Lead

KSN - Surveying

- Kris Nehmer – (916) 403-5900
Surveying

13.0 ATTACHMENTS

ATTACHMENT A – ENVIRONMENTAL DOCUMENT SIGNATURE PAGES

ATTACHMENT B – PROJECT LOCATION MAP

ATTACHMENT C – PROPOSED PROJECT DRAWINGS

ATTACHMENT D – BRIDGE GENERAL PLAN

ATTACHMENT E – PRELIMINARY COST ESTIMATES

ATTACHMENT F – RIGHT OF WAY IMPACT EXHIBIT

ATTACHMENT G – RISK REGISTER

DRAFT

ATTACHMENT A

ENVIRONMENTAL DOCUMENT SIGNATURE PAGES

Manthey Road Bridge Replacement Project

Manthey Road Bridge Replacement Project over the San Joaquin River
in the City of Lathrop in San Joaquin County, California

BRLS-5456(016)

Bridge Number 29C-0127

Initial Study with Proposed Mitigated Negative Declaration/ Environmental Assessment



Prepared by the
State of California Department of Transportation
and City of Lathrop

The environmental review, consultation, and any other actions required by applicable Federal environmental laws for this project are being, or have been, carried out by Caltrans pursuant to 23 United States Code 327 and the Memorandum of Understanding dated December 23, 2016 and executed by the Federal Highway Administration and Caltrans.



September 2020

General Information About This Document

What's in this document:

The California Department of Transportation (Caltrans), as assigned by the Federal Highway Administration, has prepared this Initial Study/Environmental Assessment, which examines the potential environmental impacts of alternatives being considered for the proposed project in the City of Lathrop, San Joaquin County in California. The Department is the lead agency under the National Environmental Policy Act (NEPA). The City of Lathrop is the lead agency under the California Environmental Quality Act (CEQA). The document explains why the project is being proposed, what alternatives we have considered for the project, how the existing environment that could be affected by the project, potential impacts of each of the alternatives, and proposed avoidance, minimization, and/or mitigation measures.

What you should do:

- Please read the document.
- Additional copies of the document and the related technical studies are available for review at the Caltrans District 10 office at 1976 Martin Luther King Junior Boulevard, Stockton, California
- The document can also be downloaded at the following website:
<https://www.ci.lathrop.ca.us/com-dev/page/public-review-documents>.
- Tell us what you think. If you have any comments regarding the proposed project, please send your written comments to Caltrans by the deadline.
- Submit comments via United States mail to: Dominic Vitali, District 10 Environmental, California Department of Transportation, 1976 East Martin Luther King Jr. Boulevard, Stockton, California, 95205.
- Submit comments via email to: Dominic.Vitali@dot.ca.gov.
- Be sure to send comments by the deadline: October 11, 2020.

What happens next:

After comments are received from the public and reviewing agencies, Caltrans, as assigned by the Federal Highway Administration, may 1) give environmental approval to the proposed project, 2) do additional environmental studies, or 3) abandon the project. If the project is given environmental approval and funding is appropriated, the City of Lathrop could design and construct all or part of the project.

Printing this document: To save paper, this document has been set up for two-sided printing (to print the front and back of a page). Blank pages occur where needed throughout the document to maintain proper layout of the chapters and appendices.

For individuals with sensory disabilities, this document can be made available in Braille, in large print, on audiocassette, or on computer disk. To obtain a copy in one of these alternate formats, please write to or call Caltrans, Attention: Dominic Vitali, District 10 Environmental, 1976 East Martin Luther King Jr. Boulevard, Stockton, California 95205; 1-209-948-7427 (Voice), or use the California Relay Service 1-800-735-2929 (TTY to Voice), 1-800-735-2922 (Voice to TTY), 1 (800) 855-3000 (Spanish TTY to Voice and Voice to TTY), 1-800-854-7784 (Spanish and English Speech-to-Speech) or 711.

[SCH #]
BRLS-5456(016)
Bridge Number 29C-0127

Replace the Manthey Road Bridge over the San Joaquin River in the city of Lathrop
in San Joaquin County

**INITIAL STUDY WITH PROPOSED MITIGATED NEGATIVE
DECLARATION / ENVIRONMENTAL ASSESSMENT**

Submitted Pursuant to: (State) Division 13, California Public Resources Code
(Federal) 42 United States Code 4332(2)(C)

THE STATE OF CALIFORNIA
Department of Transportation
and
the City of Lathrop
Cooperating Agencies under NEPA: United States Coast Guard, United States Army
Corps of Engineers, United States Fish and Wildlife Services, National Marine
Fisheries Service
Responsible Agencies under CEQA: State Lands Commission, California
Department of Fish and Wildlife, Regional Water Quality Control Board, Reclamation
District 17, Reclamation District 2062

Date

Dennis T. Agar
Acting District Director
California Department of Transportation
NEPA Lead Agency

Date

Michael King
Director of Public Works
City of Lathrop
CEQA Lead Agency

The following may be contacted for more information about this document:

Dominic Vitali, 1976 E. Dr. Martin Luther King Jr. Blvd., Stockton, CA 95205
Michael King, 390 Towne Center Drive, Lathrop, CA 95330

DRAFT

Proposed Mitigated Negative Declaration

Pursuant to: Division 13, Public Resources Code

Project Description

The City of Lathrop (City), in coordination with Caltrans, proposes to replace the Manthey Road bridge over the San Joaquin River in the City of Lathrop to address issues of safety and circulation and to improve bicycle and pedestrian access. The bridge approach would include a portion of the proposed Golden Valley Parkway alignment.

Determination

This proposed Mitigated Negative Declaration is included to give notice to interested agencies and the public that it is the City's intent to adopt a Mitigated Negative Declaration for this project. This Mitigated Negative Declaration is subject to change based on comments received from interested agencies and the public.

The City has prepared an Initial Study for this project and, pending public review, expect to determine from this study that the proposed project would not have a significant effect on the environment for the following reasons.

The proposed project would have no effect on Land Use and Planning, Population and Housing, Recreation, and Transportation.

The proposed project would have no significant effect on Aesthetics, Agricultural Resources, Air Quality, Energy, Geology and Soils, Hazards and Hazardous Materials, Hydrology and Water Quality, Mineral Resources, Noise, Public Services, Tribal Cultural Resources, Utilities and Service Systems, and Wildfire.

The proposed project would have no significantly adverse effect on Biological Resources or Cultural Resources because the following mitigation measures would reduce potential effects to insignificance:

- Prepare and Implement a Post Review Discovery and Monitoring Plan
- Compensate for Temporary Effects on and Permanent Loss of Riparian Woodland and Riparian Scrub (Including Shaded Riverine Aquatic Cover)
- Purchase Channel Enhancement Credits at National Marine Fisheries Service-Approved Anadromous Fish and United States Fish and Wildlife Service-Approved Delta Smelt Conservation Bank for Impacts on Critical Habitat

Michael King
Director of Public Works
City of Lathrop

Date

DRAFT

ATTACHMENT B
PROJECT LOCATION MAP

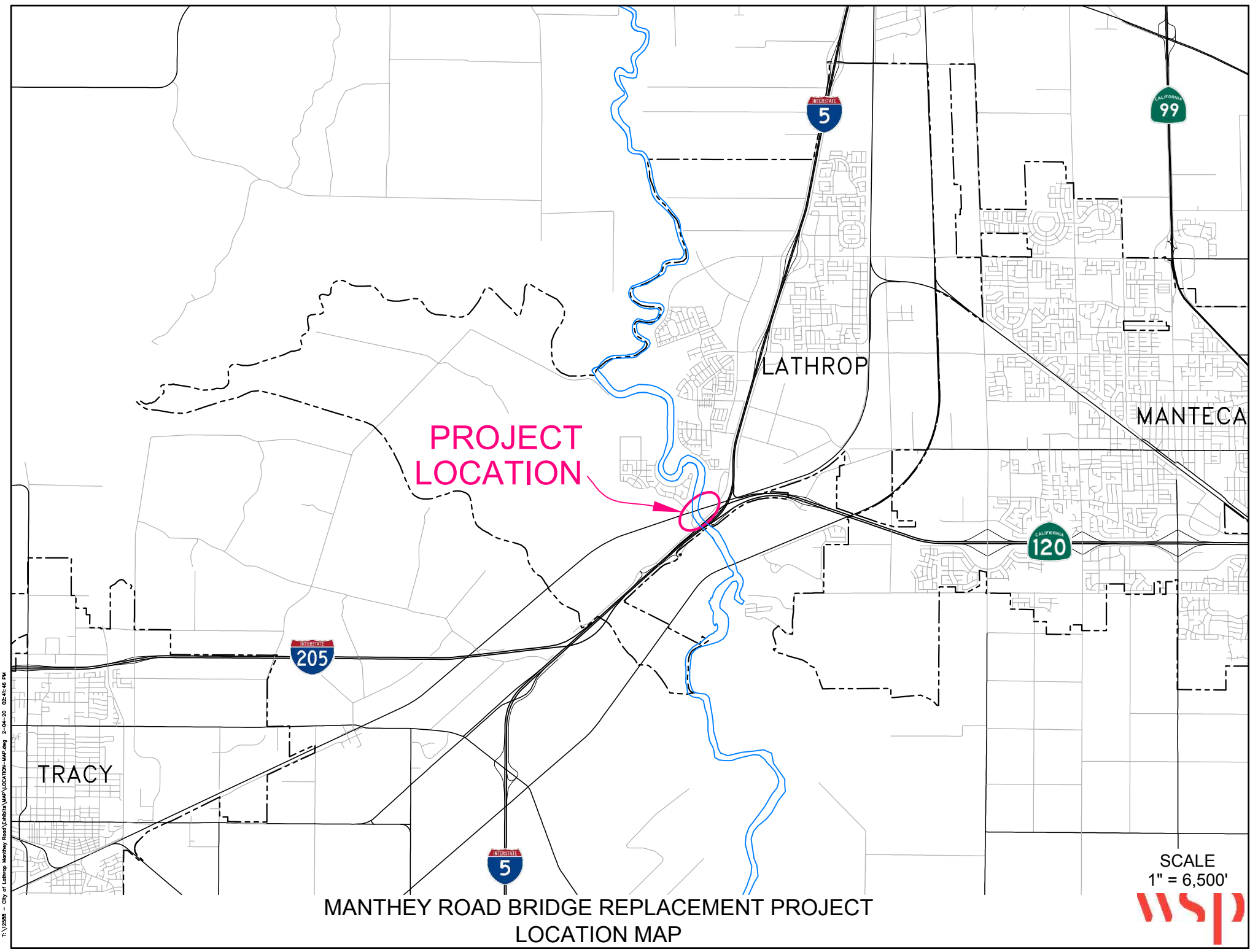

**PROJECT
LOCATION**

LATHROP

MANTECA

TRACY

**MANTHEY ROAD BRIDGE REPLACEMENT PROJECT
LOCATION MAP**

SCALE
1" = 6,500'



T:\12588 - City of Lathrop_Manthey Road_Bridges\Map\LOCATION-Map.dwg 2-04-20 02:41:46 PM

DRAFT

ATTACHMENT C
PROPOSED PROJECT DRAWINGS

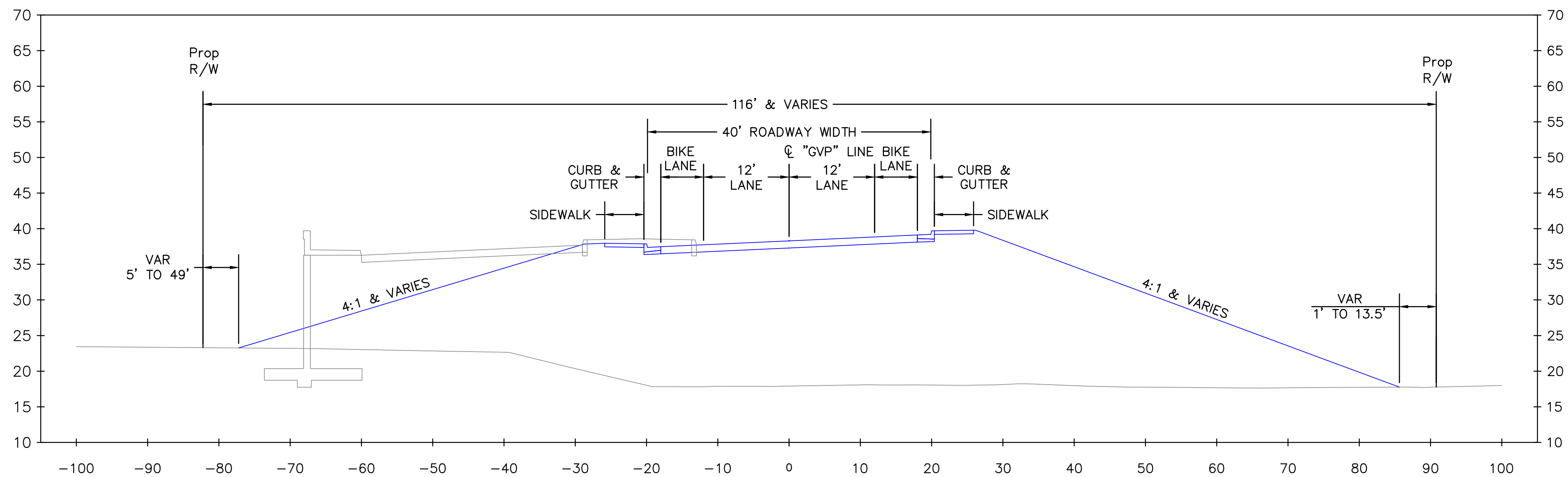

"GVP" LINE
OPTION 3 - TYPICAL SECTION

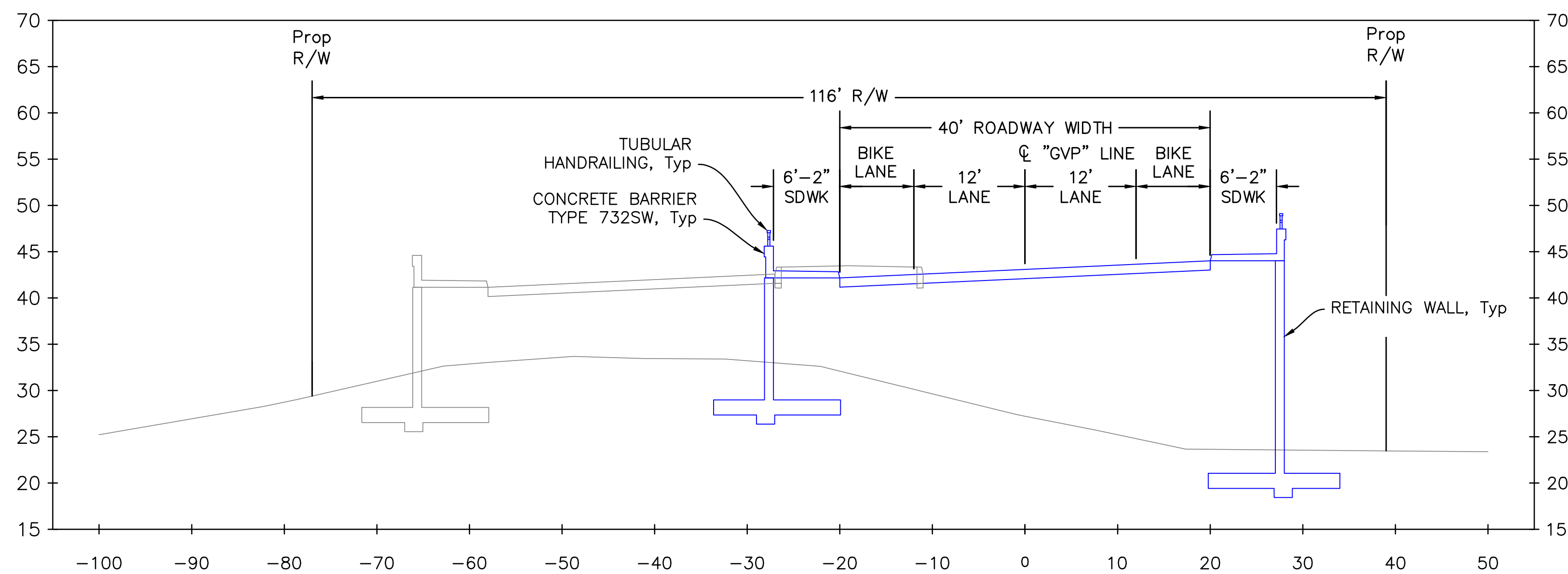

"GVP" LINE
OPTION 3 - STA 20+50.00

PRELIMINARY

2150 River Plaza Drive, Suite 400
Sacramento, CA 95833
(916) 567-2500

NUMBER	DATE	DESCRIPTION	BY

BENCHMARK ELEVATION: _____

CITY OF LATHROP
DEPARTMENT OF PUBLIC WORKS
390 Towne Centre Drive
Lathrop, CA 95330
(209) 941-7430
(209) 941-7449 FAX

DRAWN BY: J. COMEAU
DESIGNED BY: B. CONSOLACION
CHECKED BY: R. YOSHIMURA
SUBMITTED BY: A. SEYEDMADANI

SCALE:
HORIZONTAL
N.T.S.
VERTICAL
N.T.S.

MANTHEY ROAD
BRIDGE REPLACEMENT PROJECT
TYPICAL SECTIONS
ALIGNMENT ALTERNATIVE 3 "GVP" LINE

DRAWING X-1
SHEET
OF

I:\12588 - City of Lathrop - Manthey Road\CADD-Master\Civil\12588-TYP-SEC.dwg 9-22-20 02:53:02 PM

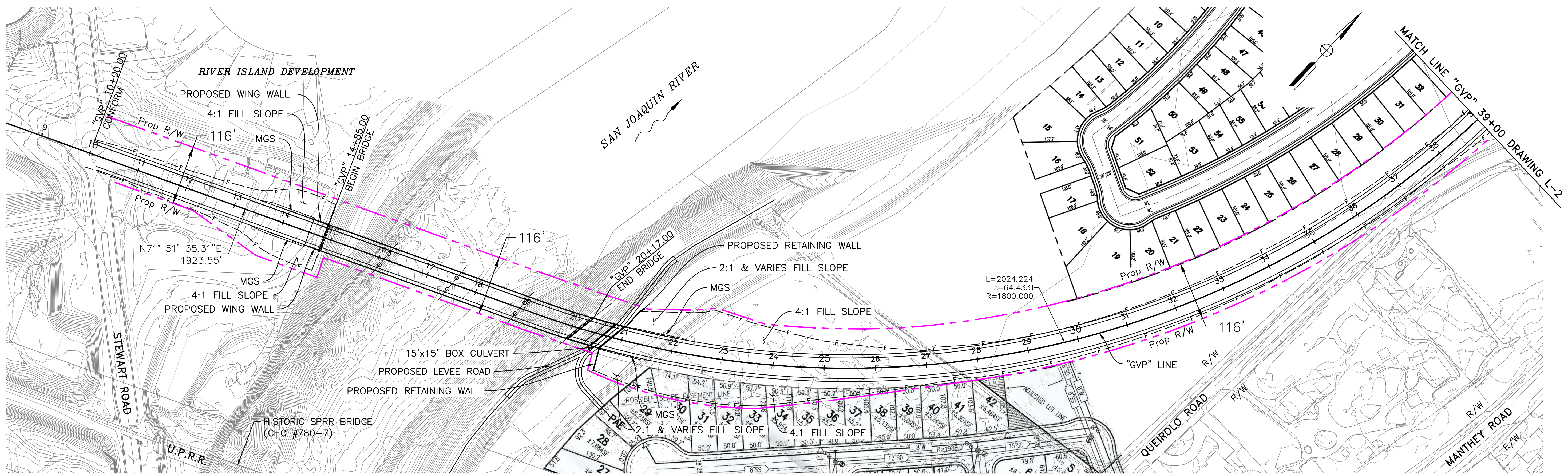

PLAN

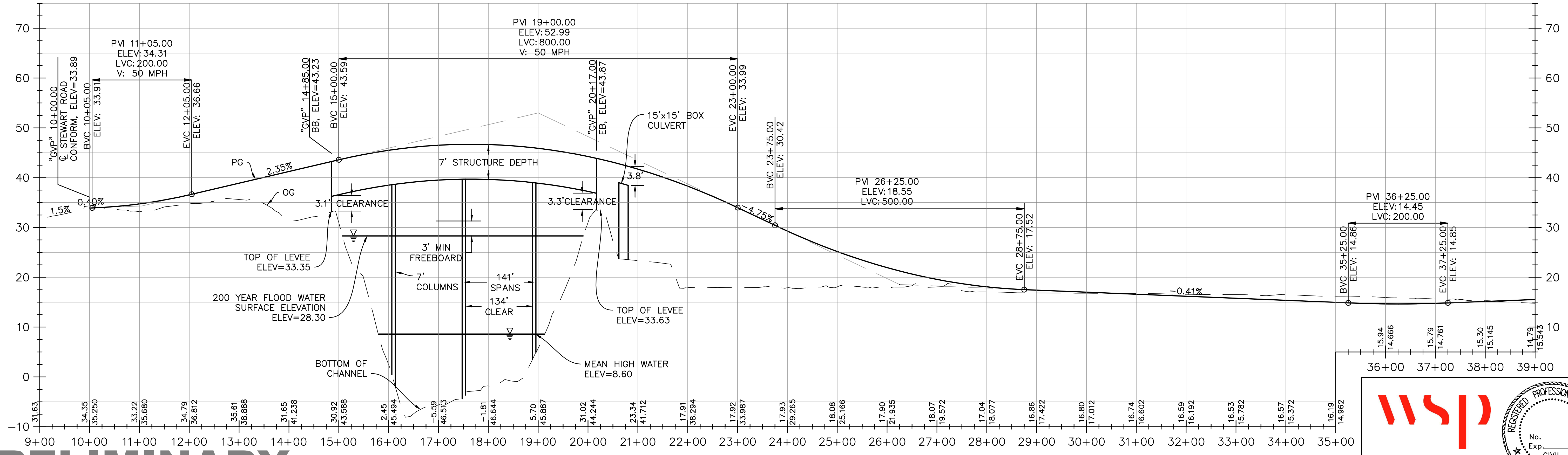

PROFILE

PRELIMINARY

NUMBER	DATE	DESCRIPTION	BY

REVISION BLK.	BENCHMARK ELEVATION:

CITY OF LATHROP
DEPARTMENT OF PUBLIC WORKS
 390 Towne Centre Drive
 Lathrop, CA 95330
 (209) 941-7430
 (209) 941-7449 FAX

DRAWN BY:	J. COMEAU
DESIGNED BY:	J. COMEAU
CHECKED BY:	R. YOSHIMURA
SUBMITTED BY:	A. SEYEDMADANI

SCALE:	HORIZONTAL	1"=100'
	VERTICAL	1"=10'

MANTHEY ROAD
BRIDGE REPLACEMENT PROJECT
PLAN AND PROFILE
ALIGNMENT ALTERNATIVE 3 "GVP" LINE

DRAWING	L-1
SHEET	
OF	

2150 River Plaza Drive, Suite 400
 Sacramento, CA 95833
 (916) 567-2500

C:\Users\comeau\Documents\Monthly\12568-ALT 3 Layout.dwg 5-04-20 11:03:09 AM

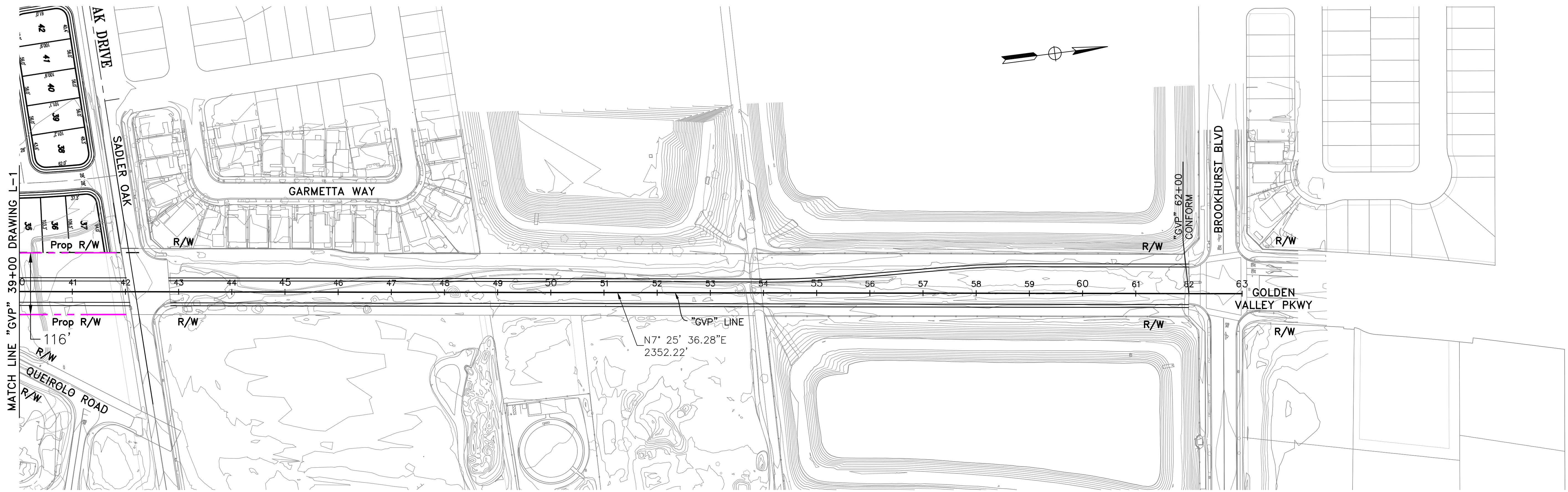

PLAN

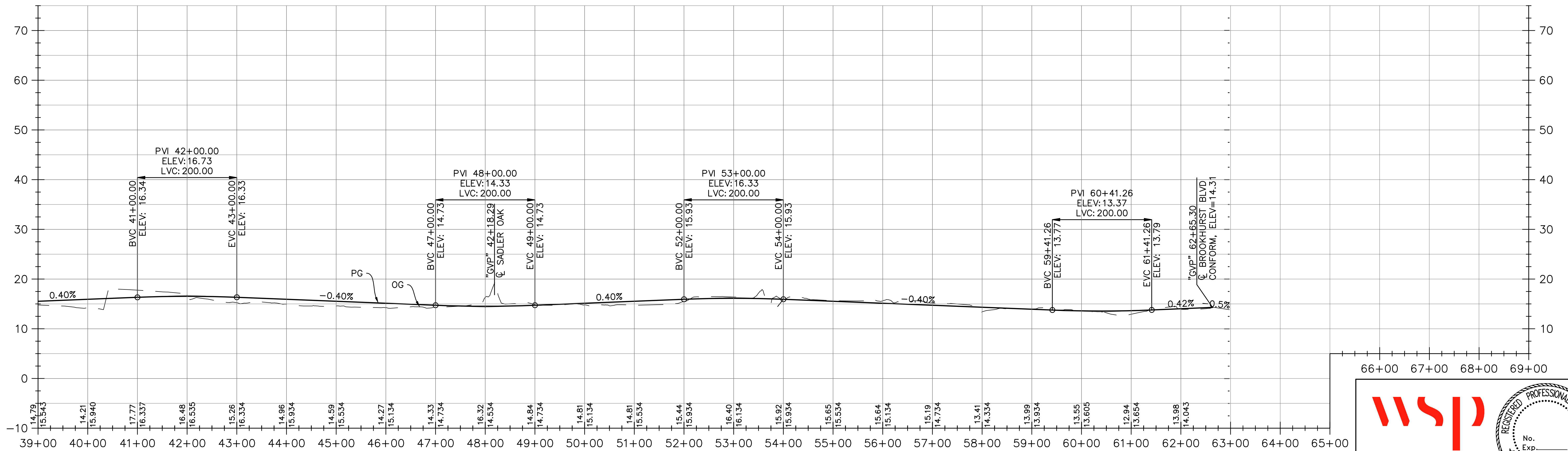

PROFILE

PRELIMINARY

NUMBER	DATE	DESCRIPTION	BY

REVISION BLK.	BENCHMARK ELEVATION: _____
---------------	----------------------------

CITY OF LATHROP
 DEPARTMENT OF PUBLIC WORKS
 390 Towne Centre Drive
 Lathrop, CA 95330
 (209) 941-7430
 (209) 941-7449 FAX

DRAWN BY:	J. COMEAU
DESIGNED BY:	J. COMEAU
CHECKED BY:	R. YOSHIMURA
SUBMITTED BY:	A. SEYEDMADANI

SCALE:	HORIZONTAL	1"=100'
	VERTICAL	1"=10'

MANTHEY ROAD
BRIDGE REPLACEMENT PROJECT
PLAN AND PROFILE
ALIGNMENT ALTERNATIVE 3 "GVP" LINE

DRAWING	L-2
SHEET	OF

C:\Users\comeau\Documents\Monthly\12568-ALT 3 Layout.dwg 5-04-20 11:13:44 AM

DRAFT

ATTACHMENT D
BRIDGE GENERAL PLAN

INDEX TO PLANS

DRAWING NO.	TITLE
S-1	GENERAL PLAN
S-2	GENERAL PLAN (CIP PS BOX GIRDER ALTERNATIVE)
S-3	FOUNDATION PLAN

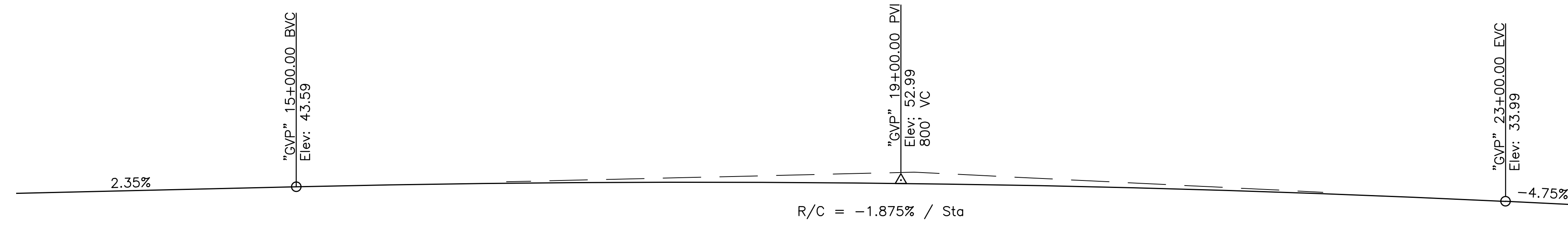

PROFILE GRADE

NOT TO SCALE

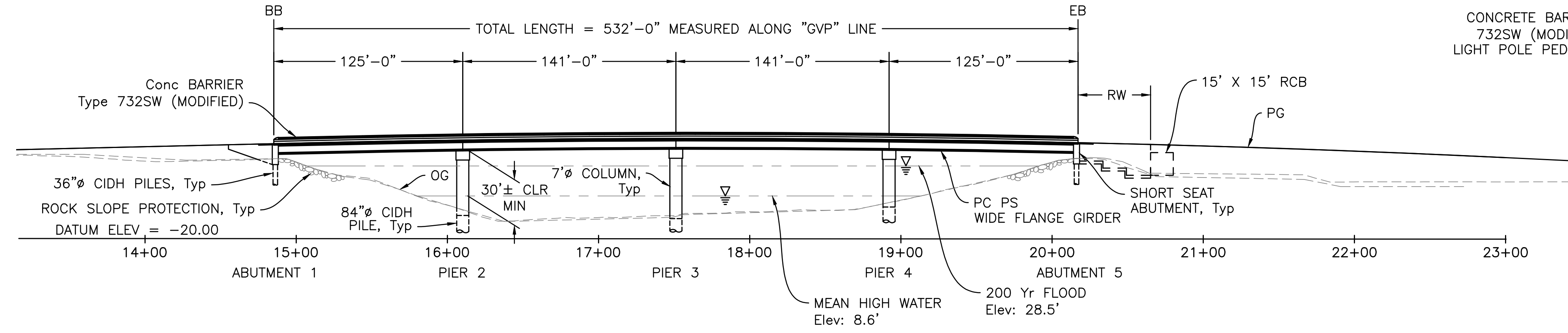

DEVELOPED ELEVATION

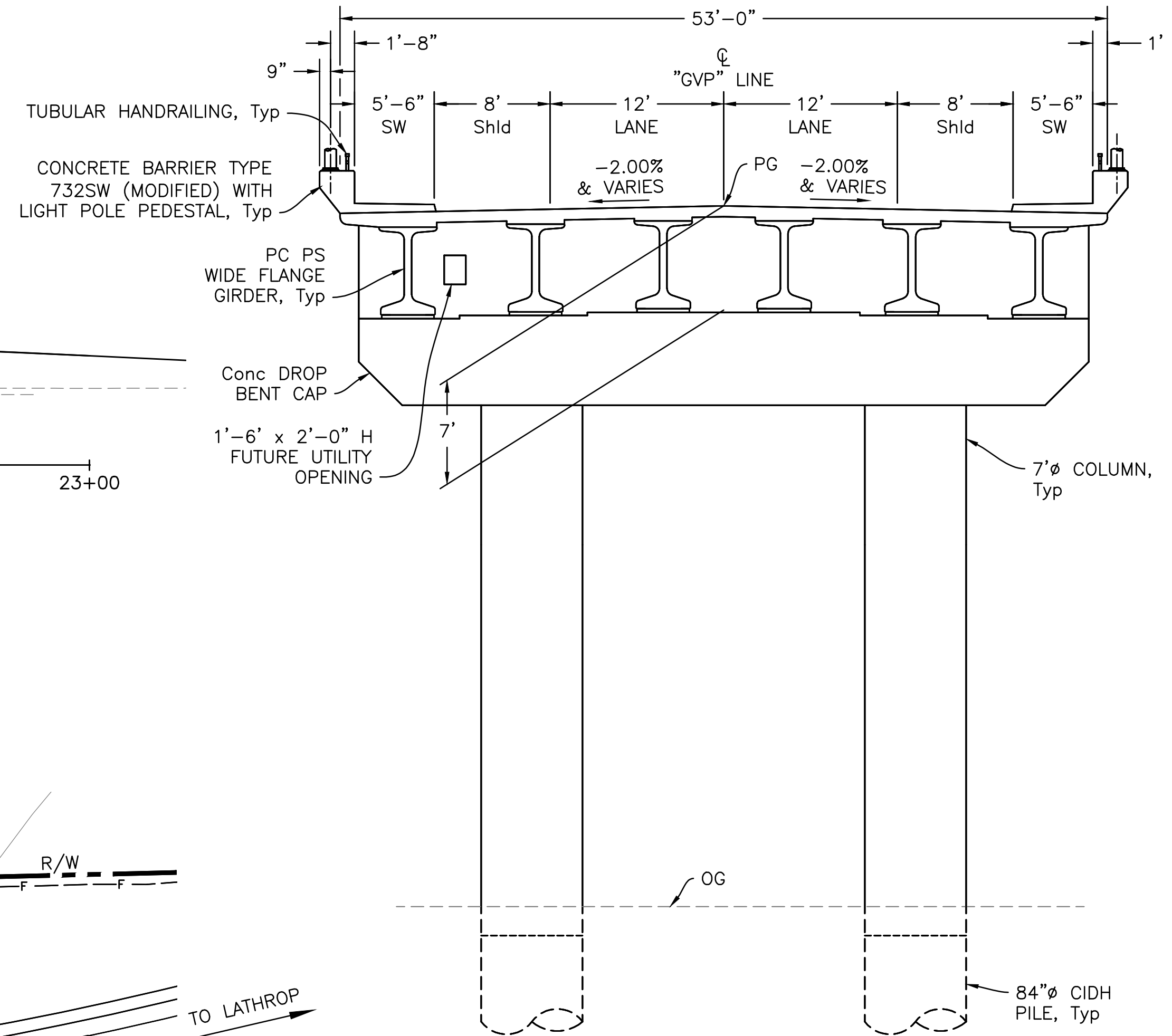

TYPICAL SECTION

NOT TO SCALE

▲ "GVP" LINE CURVE DATA

R = 1800.00'
Δ = 64°25'59"
T = 1134.25'
L = 2024.22'

NOTE
See Caltrans Standard Plan A10A & A10B for abbreviations.

LEGEND

- NEW STRUCTURE
- ~ INDICATES DIRECTION OF FLOW

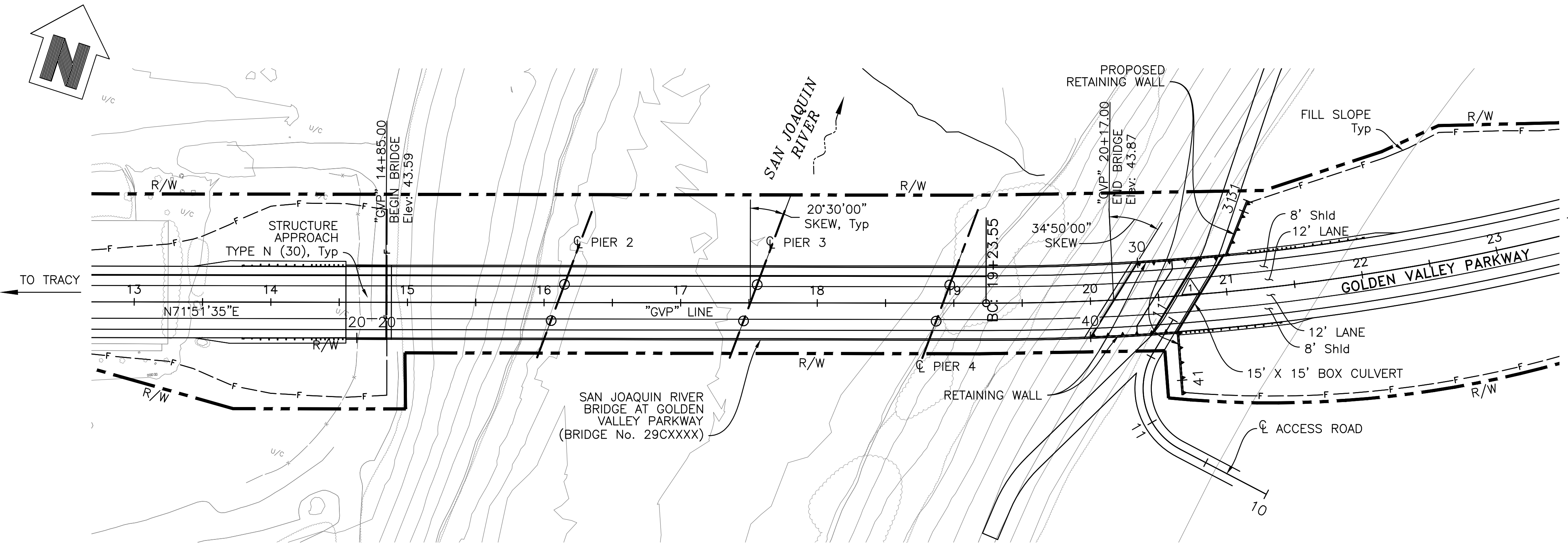

PLAN

T: 122688 - City of Lathrop, Manthey Road CAD-Structural\12588-01-CP.dwg 9-01-20 07:21:29 PM

NUMBER	DATE	DESCRIPTION	BY

BENCHMARK ELEVATION: _____

CITY OF LATHROP
DEPARTMENT OF PUBLIC WORKS

390 Towne Centre Drive
Lathrop, CA 95330
(209) 941-7430
(209) 941-7449 FAX

DRAWN BY:	P. TAM
DESIGNED BY:	B. SHAHLA
CHECKED BY:	B. CONSOLACION
SUBMITTED BY:	A. SEYEDMADANI

SCALE:	HORIZONTAL 1"=50'
VERTICAL	1"=50'

MANTHEY ROAD
BRIDGE REPLACEMENT PROJECT

GENERAL PLAN
PC PS WIDE FLANGE GIRDER

2150 River Plaza Drive, Suite 400
Sacramento, CA 95833
(916) 567-2500

DRAWING	S-1
SHEET	1
OF	3

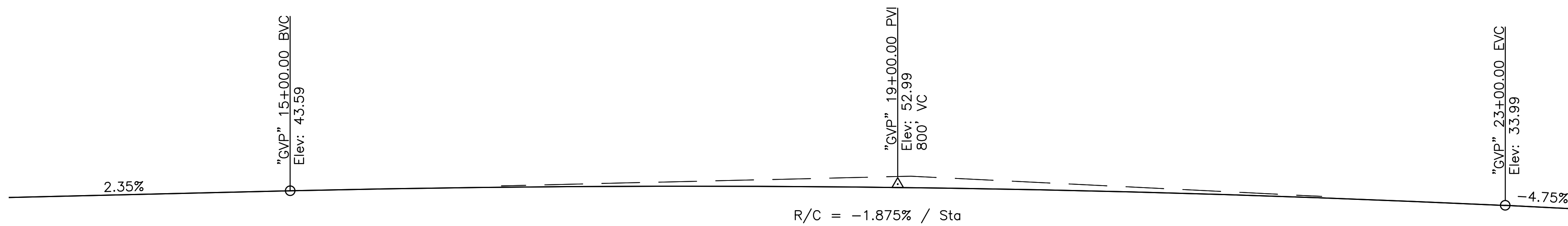

PROFILE GRADE
NOT TO SCALE

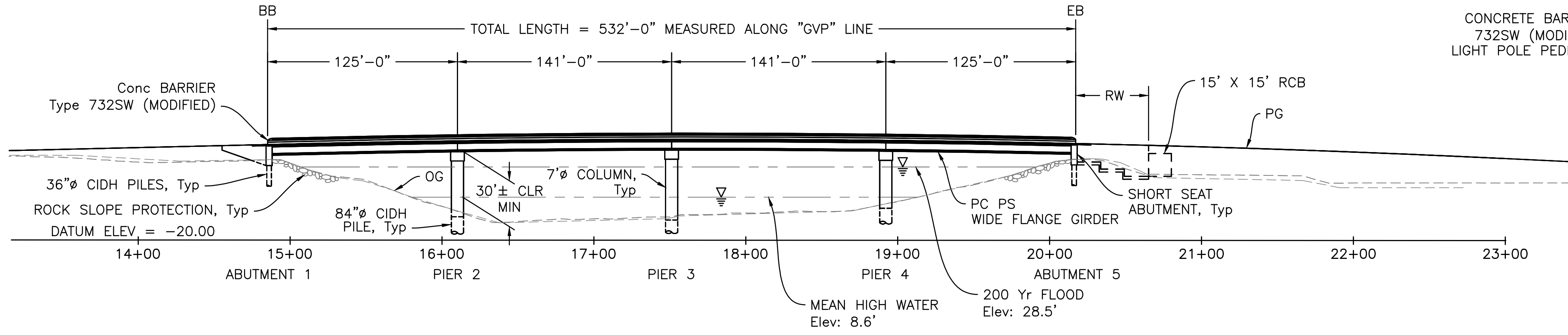

DEVELOPED ELEVATION

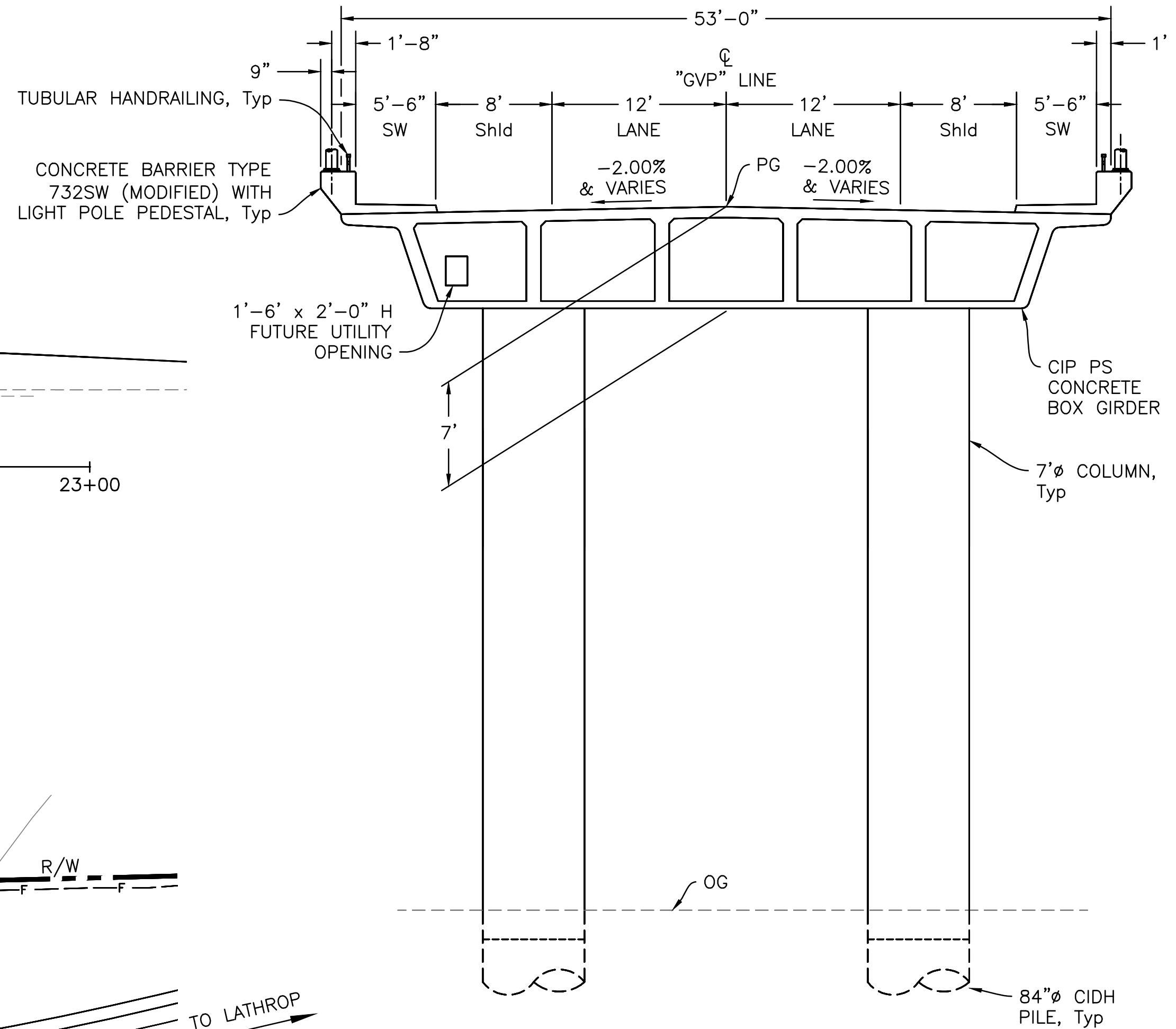

TYPICAL SECTION
NOT TO SCALE

"GVP" LINE CURVE DATA
 R = 1800.00'
 Δ = 64°25'59"
 T = 1134.25'
 L = 2024.22'

NOTE
See Caltrans Standard Plan A10A & A10B for abbreviations.

LEGEND

- NEW STRUCTURE
- ~ INDICATES DIRECTION OF FLOW

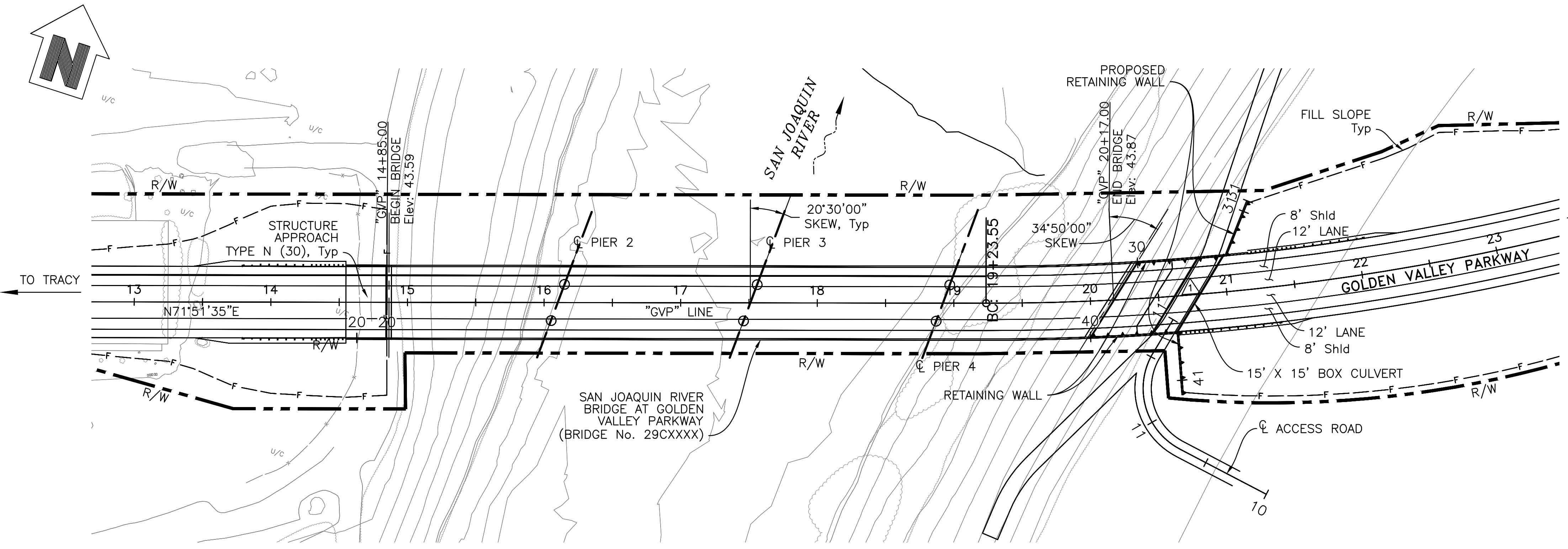

PLAN

WSP

2150 River Plaza Drive, Suite 400
Sacramento, CA 95833
(916) 567-2500

REGISTERED PROFESSIONAL ENGINEER
No. Exp. CIVIL
STATE OF CALIFORNIA

NUMBER	DATE	DESCRIPTION	BY

BENCHMARK ELEVATION: _____

CITY OF LATHROP
DEPARTMENT OF PUBLIC WORKS

390 Towne Centre Drive
Lathrop, CA 95330
(209) 941-7430
(209) 941-7449 FAX

DRAWN BY: P. TAM
 DESIGNED BY: B. SHAHLA
 CHECKED BY: B. CONSOLACION
 SUBMITTED BY: A. SEYEDMADANI

SCALE:
HORIZONTAL
1"=50'
VERTICAL
1"=50'

MANTHEY ROAD
BRIDGE REPLACEMENT PROJECT

GENERAL PLAN
CIP PS BOX GIRDER ALTERNATIVE

DRAWING S-2
SHEET 2 OF 3

T: 1/2/2008 - City of Lathrop, Manthey Road CAD-Structural\12588-02-CP.dwg 9-01-20 07:09:59 PM

PILE DATA TABLE

Location	Pile Type	Nominal Resistance (kips)		Specified Tip Elevation (ft)	Design Tip Elevation (ft)	Cut-Off Elevation (ft)
		Compression	Tension			
Abut 1	36" CIDH	614	0	-28	(a) -28 (d) x	29.42
Pier 2	84" CIDH	3900	0	-113	(a) -113 (d) x	-4
Pier 3	84" CIDH	4143	0	-120	(a) -120 (d) x	-6.4
Pier 4	84" CIDH	3900	0	-108	(a) -108 (d) x	1.49
Abut 5	36" CIDH	614	0	-28	(a) -28 (d) x	29.81

NOTE: Design tip elevations are controlled by: (a) Compression, (b) Tension, (c) Settlement and (d) Lateral Load.

HYDROLOGY SUMMARY TABLE

Hydrology Summary for Bridge No. 29CXXXX			
Drainage Area: 14,200 mi ²			
Frequency	Design Flood	Base Flood	Flood of Record
	50-year	100-year	200-year
Discharge	-	58,300 cfs	66,000 cfs
Water Surface Elevation at Bridge	-	27.4 ft	28.1 ft

Floodplain data are based upon information available when the plans were prepared and are shown to meet federal requirements. The accuracy of said information is not warranted by the State and interested or affected parties should make their own investigation.

LEGEND:

- 36" CIDH PILE
- 84" CIDH PILE
- DIRECTION OF FLOW

△ "GVP" LINE CURVE DATA

R = 1800.00'
 Δ = 64°25'59"
 T = 1134.25'
 L = 2024.22'

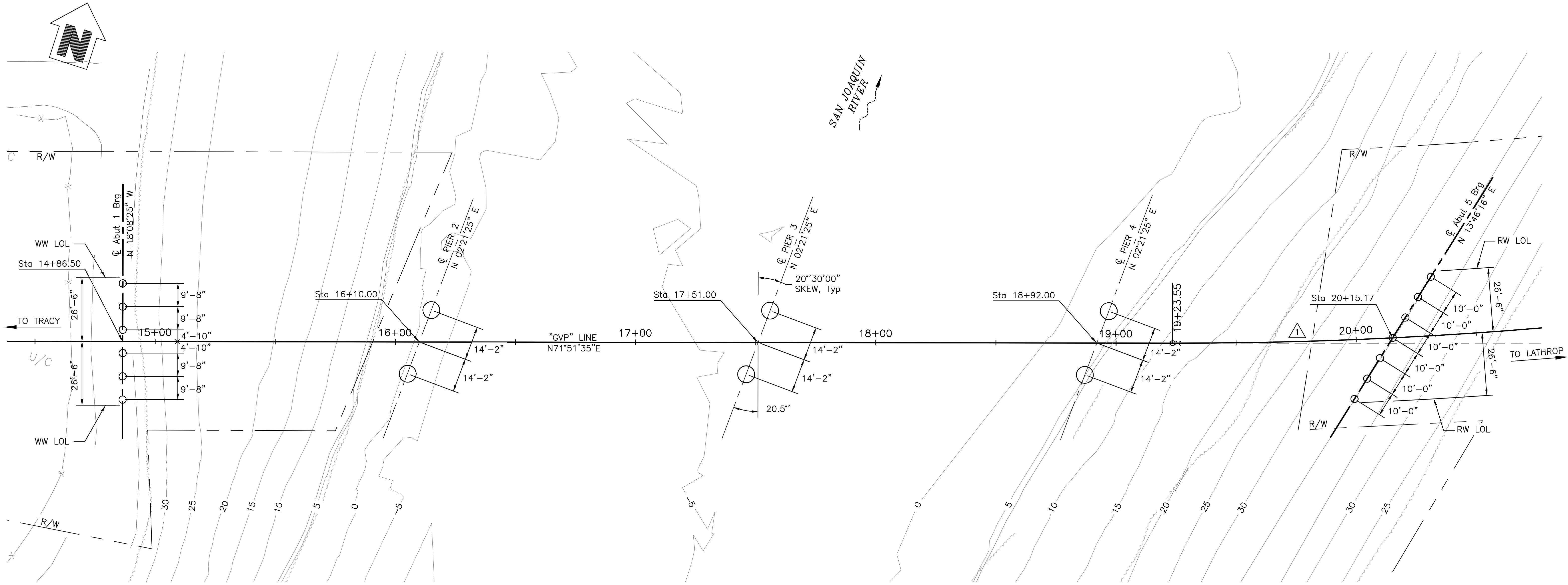

PLAN

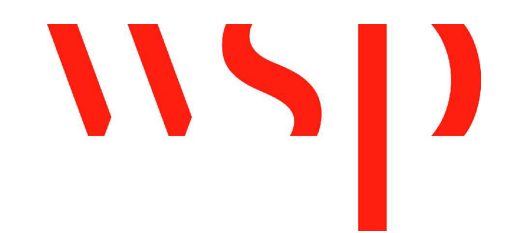

2150 River Plaza Drive, Suite 400
 Sacramento, CA 95833
 (916) 567-2500

I:\12588 - City of Lathrop - Manthey Road\CADD-Sheet\Structural\12588-03-FP.dwg 9-01-20 11:36:57 AM

BENCHMARK ELEVATION: _____						DRAWN BY: P. TAM DESIGNED BY: B. SHAHLA CHECKED BY: B. CONSOLACION SUBMITTED BY: A. SEYEDMADANI	
CITY OF LATHROP DEPARTMENT OF PUBLIC WORKS 390 Towne Centre Drive Lathrop, CA 95330 (209) 941-7430 (209) 941-7449 FAX				SCALE: HORIZONTAL 1"=20' VERTICAL 1"=20'		MANTHEY ROAD BRIDGE REPLACEMENT PROJECT FOUNDATION PLAN	
REVISION BLK. NUMBER DATE DESCRIPTION BY				DRAWING S-3 SHEET 3 OF 3			

DRAFT

ATTACHMENT E

PRELIMINARY COST ESTIMATE

I. ROADWAY ITEMS SUMMARY

Section	Cost
1 Earthwork	\$ 1,054,853
2 Pavement Structural Section	\$ 3,309,925
3 Drainage	\$ 550,000
4 Specialty Items	\$ 1,055,629
5 Landscaping, Irrigation, and NPDES	\$ 415,000
6 Traffic Items	\$ 482,652
7 Detours	\$ 75,000
8 Minor Items	-
9 Roadway Mobilization	\$ 694,306
10 Supplemental Work	\$ 355,153
11 State Furnished	\$ 115,000
12 Time-Related Overhead	\$ 913,453
13 Roadway Contingencies	\$1,353,146
TOTAL ROADWAY ITEMS	
\$ 10,374,116	

Estimate Prepared By :	Ryan Yoshimura, Project Engineer	5/4/2020	916-567-2500
	Name and Title	Date	Phone
Estimate Updated By :	Hossein Ghafourian, Civil Engineer	9/23/2020	916-567-2561
	Name and Title	Date	Phone
Estimate Reviewed By :	James D. Gomez, Senior Engineering Manager	9/23/2020	916-567-2593
	Name and Title	Date	Phone

SECTION 1: EARTHWORK

Item code		Unit	Quantity		Unit Price (\$)		Cost
160101	Clearing & Grubbing	LS	1	x	50,000.00	= \$	50,000
XXXXX	Demo Existing Building (APN 241-020-63)	LS	1	x		= \$	-
170101	Develop Water Supply	LS	1	x	10,000.00	= \$	10,000
190101	Roadway Excavation	CY	2,000	x	75.00	= \$	150,000
190103	Roadway Excavation (Type Y) ADL	CY		x		= \$	-
190105	Roadway Excavation (Type Z-2) ADL	CY		x		= \$	-
192025	Structure Excavation (Culvert)	CY	247	x	140.00	= \$	34,580
192037	Structure Excavation (Retaining Wall)	CY	112	x	195.00	= \$	21,840
192502	Sand Bedding	CY	14	x	200.00	= \$	2,800
193004	Structural Backfill (Culvert)	CY	675	x	190.00	= \$	128,250
193013	Structure Backfill (Retaining Wall)	CY	409	x	135.00	= \$	55,215
193031	Pervious Backfill Material (Retaining Wall)	CY	243	x	130.00	= \$	31,537
194001	Ditch Excavation	CY		x		= \$	-
198010	Imported Borrow (CY)	CY	15,732	x	35.00	= \$	550,631
198007	Imported Material (Shoulder Backing)	TON		x		= \$	-
180106	Dust Palliative	LS	1	x	20,000.00	= \$	20,000

TOTAL EARTHWORK SECTION ITEMS	\$	1,054,853
--------------------------------------	-----------	------------------

SECTION 2: PAVEMENT STRUCTURAL SECTION

Item code		Unit	Quantity		Unit Price (\$)		Cost
150771	Remove Asphalt Concrete Dike	LF		x		= \$	-
150860	Remove Base and Surfacing	CY		x		= \$	-
153103	Cold Plane Asphalt Concrete Pavement	SQYD		x		= \$	-
1532XX	Remove Concrete (type)	CY		x		= \$	-
250401	Class 4 Aggregate Subbase	CY		x		= \$	-
260203	Class 2 Aggregate Base (CY)	CY	11,032	x	100.00	= \$	1,103,243
290201	Asphalt Treated Permeable Base	CY		x		= \$	-
365001	Sand Cover	TON		x		= \$	-
374002	Asphaltic Emulsion (Fog Seal Coat)	TON		x		= \$	-
374492	Asphaltic Emulsion (Polymer Modified)	TON		x		= \$	-
3750XX	Screenings (Type XX)	TON		x		= \$	-
377501	Slurry Seal	TON		x		= \$	-
390095	Replace Asphalt Concrete Surfacing	CY		x		= \$	-
390132	Hot Mix Asphalt (Type A)	TON	7,154	x	150.00	= \$	1,073,048
390136	Minor Hot Mix Asphalt	TON		x		= \$	-
390137	Rubberized Hot Mix Asphalt (Gap Graded)	TON		x		= \$	-
393003	Geosynthetic Pavement Interlayer	SQYD		x		= \$	-
39405X	Shoulder Rumber Strip (HMA, Type XX Indent	STA		x		= \$	-
394071	Place Hot Mix Asphalt Dike	LF		x		= \$	-
394090	Place Hot Mix Asphalt (Misc. Area)	SQYD		x		= \$	-
397005	Tack Coat	TON		x		= \$	-
401000	Concrete Pavement	CY		x		= \$	-
401108	Replace Concrete Pavement (Rapid Strength	CY		x		= \$	-
404092	Seal Pavement Joint	LF		x		= \$	-
404094	Seal Longitudinal Isolation Joint	LF		x		= \$	-
413112A	Repair Spalled Joints (Polyester Grout)	SQYD		x		= \$	-
413115	Seal Existing Concrete Pavement Joint	LF		x		= \$	-
420102	Groove Existing Concrete Pavement	SQYD		x		= \$	-
420201	Grind Existing Concrete Pavement	SQYD		x		= \$	-
731502	Minor Concrete (Misc. Const)	CY		x		= \$	-
731504	Minor Concrete (Curb and Gutter)	CY	521	x	900.00	= \$	469,221
731521	Minor Concrete (Sidewalk)	CY	810	x	820.00	= \$	664,414
731530	Minor Concrete (Textured Paving)	SQFT		x		= \$	-
XXXXXX	Some Item			x		= \$	-

TOTAL STRUCTURAL SECTION ITEMS	\$	3,309,925
---------------------------------------	-----------	------------------

SECTION 3: DRAINAGE

Item code	Unit	Quantity	Unit Price (\$)	Cost
150206	Abandon Culvert	LF	x	= \$ -
150805	Remove Culvert	LF	x	= \$ -
150820	Modify Inlet	EA	x	= \$ -
152430	Adjust Inlet	LF	x	= \$ -
155003	Cap Inlet	EA	x	= \$ -
193114	Sand Backfill	CY	x	= \$ -
510502	Minor Concrete (Minor Structure)	CY	x	= \$ -
510512	Minor Concrete (Box Culvert)	CY	x	= \$ -
62XXXX	XXX" APC Pipe	LF	x	= \$ -
64XXXX	XXX" Plastic Pipe	LF	x	= \$ -
65XXXX	XXX" RCP Pipe	LF	x	= \$ -
66XXXX	XXX" CSP Pipe	LF	x	= \$ -
68XXXX	Edge Drain	LF	x	= \$ -
69XXXX	XXX" Pipe Downdrain	LF	x	= \$ -
70XXXX	XXX" Pipe Inlet	LF	x	= \$ -
70XXXX	XXX" Pipe Riser	LF	x	= \$ -
70XXXX	XXX" Flared End Section	EA	x	= \$ -
703233	Grated Line Drain	LF	x	= \$ -
720121	Rock Slope Protection (1/2 Ton, Method A)	CY	x	= \$ -
721420	Concrete (Ditch Lining)	CY	x	= \$ -
721430	Concrete (Channel Lining)	CY	x	= \$ -
729011	Rock Slope Protection Fabric (Class 8)	SQYD	x	= \$ -
750001	Miscellaneous Iron and Steel	LB	x	= \$ -
XXXXXX	Drainage	LS	1 x 550,000.00	= \$ 550,000
XXXXXX	Some Item		x	= \$ -

TOTAL DRAINAGE ITEMS	\$	550,000
-----------------------------	-----------	----------------

SECTION 4: SPECIALTY ITEMS

Item code	Unit	Quantity	Unit Price (\$)	Cost
070012	Progress Schedule (Critical Path Method)	LS	x	= \$ -
150662	Remove Metal Beam Guard Railing	LF	x	= \$ -
150668	Remove Terminal Systems	EA	x	= \$ -
1532XX	Remove Barrier (<i>Insert Type</i>)	LF	x	= \$ -
153250	Remove Sound Wall	SQFT	x	= \$ -
190110	Lead Compliance Plan	LS	x	= \$ -
49XXXX	CIDH Concrete Piling (<i>Insert Diameter</i>)	LF	x	= \$ -
510060	Structural Concrete (Retaining Wall)	CY	198 x 1,300.00	= \$ 257,400
510090	Structural Concrete (Box Culvert)	CY	420 x 1,300.00	= \$ 546,000
510133	Class 2 Concrete (Retaining Wall)	CY	x	= \$ -
510524	Minor Concrete (Sound Wall)	CY	x	= \$ -
5110XX	Architectural Treatment (<i>Insert Type</i>)	SQFT	x	= \$ -
511048	Apply Anti-Graffiti Coating	SQFT	x	= \$ -
5136XX	Reinforced Concrete Crib Wall (<i>Insert Type</i>)	SQFT	x	= \$ -
518002	Sound Wall (Masonry Block)	SQFT	x	= \$ -
520103	Bar Reinf. Steel (Retaining Wall)	LB	20,648 x 1.50	= \$ 30,972
520107	Bar Reinf. Steel (Box Culvert)	LB	82,278 x 1.50	= \$ 123,417
80XXXX	Fence (<i>Insert Type</i>)	LF	x	= \$ -
832001	Metal Beam Guard Railing	LF	x	= \$ -
833088	Tubular Handrailing	LF	92 x 145.00	= \$ 13,340
839310	Double Thrie Beam Barrier	LF	x	= \$ -
839521	Cable Railing	LF	100 x 85.00	= \$ 8,500
839540	Transition Railing (Type WB-31)	EA	4 x 5,300.00	= \$ 21,200
839584	Alternative In-line Terminal System	EA	4 x 4,500.00	= \$ 18,000
839581	End Anchor Assembly (<i>Type SFT</i>)	EA	x	= \$ -
839561	Rail Tensioning Assembly	EA	x	= \$ -
839XXX	Crash Cushion (<i>Insert Type</i>)	EA	x	= \$ -
839719	Concrete Barrier (<i>Type 732SW</i>)	LF	92 x 400.00	= \$ 36,800
XXXXXX	Some Item		x	= \$ -

TOTAL SPECIALTY ITEMS	\$	1,055,629
------------------------------	-----------	------------------

SECTION 5: Landscaping, Irrigation, and NPDES

5A - LANDSCAPE AND IRRIGATION

Item code	Unit	Quantity	Unit Price (\$)	Cost
200001 Highway Planting	LS	x	= \$	-
20XXXX XXX" (Insert Type) Conduit (Use for Irrigation x-overs)	LF	x	= \$	-
20XXXX Extend XXX" (Insert Type) Conduit (Use for Extension of Irrigation x-overs)	LF	x	= \$	-
201700 Imported Topsoil	CY	x	= \$	-
2030XX Erosion Control (Type __)	SQYD	x	= \$	-
203021 Fiber Rolls	LF	x	= \$	-
203026 Move In/ Move Out (Erosion Control)	EA	x	= \$	-
204099 Plant Establishment Work	LS	x	= \$	-
204101 Extend Plant Establishment (X Years)	LS	x	= \$	-
208000 Irrigation System	LS	x	= \$	-
208304 Water Meter	EA	x	= \$	-
209801 Maintenance Vehicle Pullout	EA	x	= \$	-
XXXXXX Landscaping and Irrigation	LS	1 x	150,000.00 = \$	150,000
XXXXXX Some Item		x	= \$	-
Subtotal Landscape and Irrigation				\$ 150,000

5B - NPDES

Item code	Unit	Quantity	Unit Price (\$)	Cost
074016 Construction Site Management	LS	1 x	25,000.00 = \$	25,000
074017 Prepare WPCP	LS	1 x	= \$	-
074019 Prepare SWPPP	LS	1 x	30,000.00 = \$	30,000
074023 Temporary Erosion Control	SQYD	2,000 x	= \$	-
074027 Temporary Erosion Control Blanket	SQYD	1,000 x	= \$	-
074028 Temporary Fiber Roll	LF	1,400 x	= \$	-
074032 Temporary Concrete Washout Facility	EA	2 x	= \$	-
074033 Temporary Construction Entrance	EA	2 x	= \$	-
074035 Temporary Check Dam	LF	x	= \$	-
074037 Move In/ Move Out (Temporary Erosion Control)	EA	2 x	= \$	-
074038 Temp. Drainage Inlet Protection	EA	x	= \$	-
074041 Street Sweeping	LS	1 x	= \$	-
074042 Temporary Concrete Washout (Portable)	LS	x	= \$	-
066597 Storm Water Sampling and Analysis***	LS	1 x	75,000.00 = \$	75,000
130310 Rain Event Action Plan	LS	1 x	35,000.00 = \$	35,000
130330 Storm Water Annual Report	LS	1 x	25,000.00 = \$	25,000
XXXXXX Temporary Erosion Control	LS	1 x	75,000.00 = \$	75,000

Supplemental Work for NPDES

(These costs are not accounted in total here but under Supplemental Work on sheet 7 of 11).

066595 Water Pollution Control Maintenance Sharing*	LS	x	= \$	-
066596 Additional Water Pollution Control**	LS	1 x	3,000.00 = \$	3,000
XXXXXX Some Item				

Subtotal NPDES (Without Supplemental Work) \$ 265,000

*Applies to all SWPPPs and those WPCPs with sediment control or soil stabilization BMPs.

**Applies to both SWPPPs and WPCP projects.

*** Applies only to project with SWPPPs.

TOTAL ENVIRONMENTAL \$ 415,000

SECTION 6: TRAFFIC ITEMS

6A - Traffic Electrical

Item code	Unit	Quantity	Unit Price (\$)	Cost
150760 Remove Sign Structure	EA	x	= \$	-
151581 Reconstruct Sign Structure	EA	x	= \$	-
152641 Modify Sign Structure	EA	x	= \$	-
5602XX Furnish Sign Structure	LB	x	= \$	-
5602XX Install Sign Structure	LB	x	= \$	-
56XXXX XXX" CIDHC Pile (Sign Foundation)	LF	x	= \$	-
860090 Maintain Existing Traffic Management System Elements During Construction	LS	x	= \$	-
860810 Inductive Loop Detectors	EA	x	= \$	-
86055X Lighting & Sign Illumination	LS	x	= \$	-
8607XX Interconnection Facilities	LS	x	= \$	-
8609XX Traffic Monitoring Stations	LS	x	= \$	-
870400 Signal and Lighting System	EA	2 x	175,000.00 = \$	350,000
8611XX Ramp Metering System (Location X)	LS	x	= \$	-
8611XX Ramp Metering System (Location X)	LS	x	= \$	-
86XXXX Fiber Optic Conduit System	LS	x	= \$	-
XXXXX Some Item				
<i>Subtotal Traffic Electrical</i>				<u>\$ 350,000</u>

6B - Traffic Signing and Striping

Item code	Unit	Quantity	Unit Price (\$)	Cost
120090 Construction Area Signs	LS	1 x	10,000.00 = \$	10,000
150701 Remove Yellow Painted Traffic Stripe	LF	x	= \$	-
150710 Remove Traffic Stripe	LF	x	= \$	-
150713 Remove Pavement Marking	SQFT	x	= \$	-
150742 Remove Roadside Sign	EA	x	= \$	-
152320 Reset Roadside Sign	EA	x	= \$	-
152390 Relocate Roadside Sign	EA	x	= \$	-
566011 Roadside Sign (One Post)	EA	6 x	500.00 = \$	3,000
566012 Roadside Sign (Two Post)	EA	x	= \$	-
560XXX Furnish Sign Panels	SQFT	x	= \$	-
560XXX Install Sign Panels	SQFT	x	= \$	-
82010X Delineator (Class X)	EA	x	= \$	-
840505 6" Thermoplastic traffic Stripe	LF	15,326 x	2.00 = \$	30,652
<i>Subtotal Traffic Signing and Striping</i>				<u>\$ 43,652</u>

6C - Stage Construction and Traffic Handling

Item code	Unit	Quantity	Unit Price (\$)	Cost
120100 Traffic Control System	LS	1 x	50,000.00 = \$	50,000
120120 Type III Barricade	EA	4 x	250.00 = \$	1,000
120143 Temporary Pavement Delineation	LF	x	= \$	-
12016X Channelizer	EA	x	= \$	-
128650 Portable Changeable Message Signs	EA	2 x	9,500.00 = \$	19,000
129000 Temporary Railing (Type K)	LF	200 x	45.00 = \$	9,000
129100 Temp. Crash Cushion Module	EA	2 x	5,000.00 = \$	10,000
129099A Traffic Plastic Drum	EA	x	= \$	-
839603A Temporary Crash Cushion (ADIEM)	EA	x	= \$	-
XXXXXX Some Item				
<i>Subtotal Stage Construction and Traffic Handling</i>				<u>\$ 89,000</u>

TOTAL TRAFFIC ITEMS	\$ 482,652
----------------------------	-------------------

SECTION 7: DETOURS

Include constructing, maintaining, and removal

Item code	Unit	Quantity	Unit Price (\$)	Cost
0713XX Temporary Fence (Type X)	LF		x = \$	-
07XXXX Temporary Drainage	LS		x = \$	-
120143 Temporary Pavement Delineation	LF		x = \$	-
1286XX Temporary Signals	EA		x = \$	-
129000 Temporary Railing (Type K)	LF		x = \$	-
190101 Roadway Excavation	CY		x = \$	-
198001 Imported Borrow	CY		x = \$	-
198050 Embankment	CY		x = \$	-
250401 Class 4 Aggregate Subbase	CY		x = \$	-
260201 Class 2 Aggregate Base	CY		x = \$	-
390132 Hot Mix Asphalt (Type A)	TON		x = \$	-
XXXXXX Detour	LS	1	x 75,000.00 = \$	75,000
TOTAL DETOURS				\$ 75,000

SUBTOTAL SECTIONS 1-7 \$ 6,943,059

SECTION 8: MINOR ITEMS

8A - Americans with Disabilities Act Items

ADA Items 0.5% \$ 34,715

8B - Bike Path Items

Bike Path Items 0.0% \$ -

8C - Other Minor Items

Other Minor Items 1.0% \$ 69,431

Total of Section 1-7 \$ 6,943,059 x 1.5% = \$ 104,146

TOTAL MINOR ITEMS \$ 104,146

SECTIONS 9: MOBILIZATION

999990 Total Section 1-8	\$ 6,943,059	x 10%	= \$ 694,306
TOTAL MOBILIZATION			\$ 694,306

SECTION 10: SUPPLEMENTAL WORK

Item code	Unit	Quantity	Unit Price (\$)	Cost
066015 Federal Trainee Program	LS		x = \$	-
066063 Traffic Management Plan - Public Information	LS	1	x 5,000.00 = \$	5,000
066090 Maintain Traffic	LS	1	x 20,000.00 = \$	20,000
066094 Value Analysis	LS		x = \$	-
066204 Remove Rock & Debris	LS		x = \$	-
066222 Locate Existing Cross-Over	LS		x = \$	-
066670 Payment Adjustments For Price Index Fluctuations	LS		x = \$	-
066700 Partnering	LS		x = \$	-
066866 Operation of Existing Traffic Management System E	LS		x = \$	-
066920 Dispute Review Board	LS		x = \$	-
XXXXXX Some Item			x = \$	-
<i>Cost of NPDES Supplemental Work specified in Section 5C</i>				= \$ 3,000
Total Section 1-8	\$ 6,943,059	5%	= \$ 347,153	
TOTAL SUPPLEMENTAL WORK			\$ 355,153	

II. STRUCTURE ITEMS

	<u>Bridge 1</u>	<u>Bridge 2</u>	
DATE OF ESTIMATE	03/27/20	03/27/20	00/00/00
Bridge Name	San Joaquin River Bridge	Manthey Road Bridge Removal	XXXXXXXXXXXXXXXXXXXX
Bridge Number	29CXXXX	29C0127	57-XXX
Structure Type	PC-PS CA Wide Flange Girder	Steel Through Truss	XXXXXXXXXXXXXXXXXXXX
Width (Feet) [out to out]	54.33 LF	33.50 LF	0.00 LF
Total Bridge Length (Feet)	532.00 LF	536.50 LF	0.00 LF
Total Area (Square Feet)	28905 SQFT	17973 SQFT	0 SQFT
Structure Depth (Feet)	7.00 LF	0.00 LF	0.00 LF
Footing Type (pile or spread)	Pile	pile	XXXXXXXXXXXXXXXXXXXX
Cost Per Square Foot	\$371.08	\$33.38	\$0.00

COST OF EACH STRUCTURE	\$10,726,056.00	\$600,000.00	\$0.00
-------------------------------	------------------------	---------------------	---------------

DATE OF ESTIMATE	00/00/00	00/00/00	00/00/00
Name	XXXXXXXXXXXXXXXXXXXX	XXXXXXXXXXXXXXXXXXXX	XXXXXXXXXXXXXXXXXXXX
Bridge Number	57-XXX	57-XXX	57-XXX
Structure Type	XXXXXXXXXXXXXXXXXXXX	XXXXXXXXXXXXXXXXXXXX	XXXXXXXXXXXXXXXXXXXX
Width (Feet) [out to out]	0.00 LF	0.00 LF	0.00 LF
Total Length (Feet)	0.00 LF	0.00 LF	0.00 LF
Total Area (Square Feet)	0 SQFT	0.00 SQFT	0.0 SQFT
Structure Depth (Feet)	0.00 LF	0.00 LF	0.00 LF
Footing Type (pile or spread)	XXXXXXXXXXXXXXXXXXXX	XXXXXXXXXXXXXXXXXXXX	XXXXXXXXXXXXXXXXXXXX
Cost Per Square Foot	\$0.00	\$0.00	\$0.00

COST OF EACH STRUCTURE	\$0.00	\$0.00	\$0.00
-------------------------------	---------------	---------------	---------------

TOTAL COST OF BRIDGES	\$11,326,000.00
------------------------------	------------------------

TOTAL COST OF BUILDINGS	\$0.00
--------------------------------	---------------

TOTAL COST OF STRUCTURES¹	\$11,326,000.00
---	------------------------

¹Structure's Estimate includes Overhead and Mobilization.
Add more sheets if needed. Call them 9a, 9b, 9c, ..., etc

IV. BIOLOGICAL MITIGATION

Fill in all of the available information from the Right of Way data sheet.

BA Measure	Jurisdiction	Acreage required	Mitigation Banks	Other Bank Options
Measure 15. Channel Enhancement Credits for Anadromous Fish and Delta Smelt	NMFS, USFWS & CDFW	1.2	\$210,000 (Liberty Island Conservation Bank @ \$175,000/ac)	Liberty Island is out of credits; North Delta Fish Conservation Bank should be available in 2021
Measure 14. Riparian Woodland/Scrub and SRA Cover	CDFW	0.47 (Incl 0.058 SRA)	\$70,500 (Cosumnes Floodplain mitigation bank @ \$150,000/ac)	Beach Lake - not enough available credits
Subtotal			\$280,500	
Contingency			\$119,500	
Total			\$400,000	

TOTAL Biological Mitigation ESTIMATE: Escalated	\$	424,360
--	-----------	----------------

DRAFT

ATTACHMENT F

RIGHT OF WAY IMPACT EXHIBIT

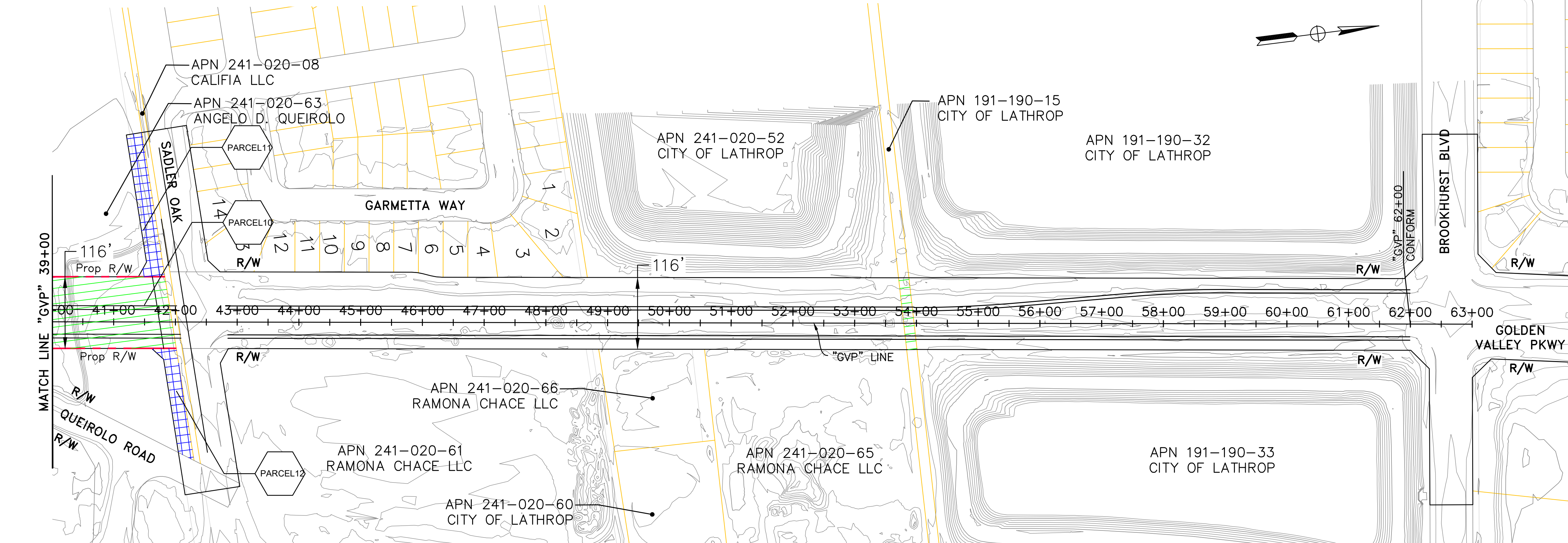
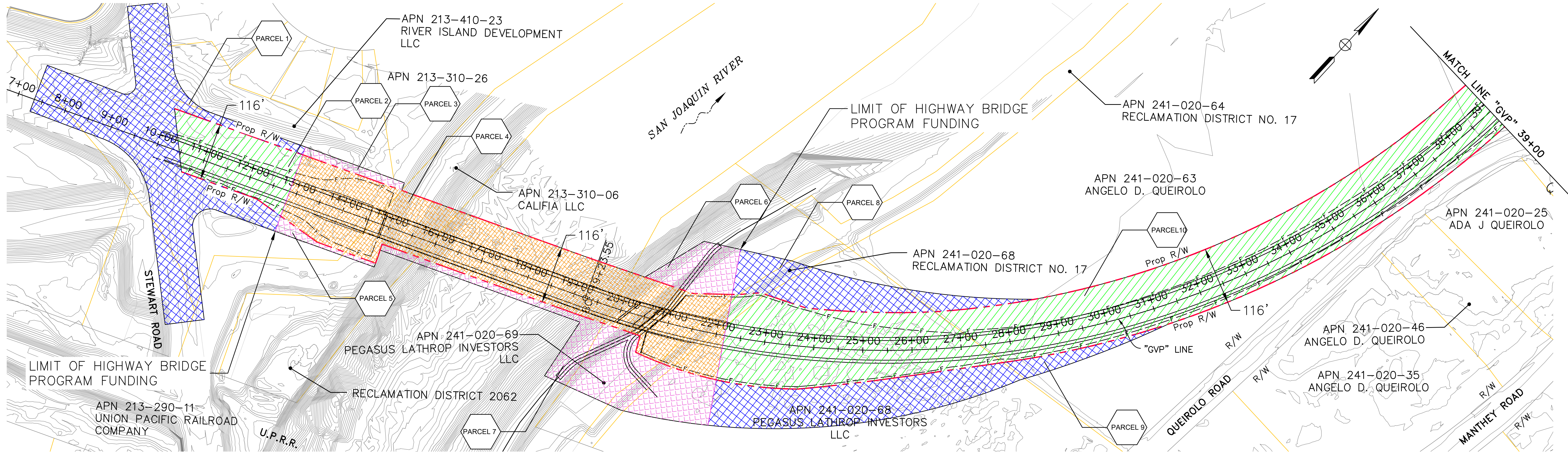

LEGEND

- EXISTING PARCEL LINES
- PROPOSED RIGHT OF WAY
- TEMPORARY CONSTRUCTION EASEMENT (NON-PARTICIPATING)
- PERMANENT RIGHT OF WAY (NON-PARTICIPATING)
- TEMPORARY CONSTRUCTION EASEMENT (PARTICIPATING)
- PERMANENT RIGHT OF WAY (PARTICIPATING)
- PERMANENT RIGHT OF WAY

PARCEL NO.	AREA (Sq.ft)
PARCEL 1	90371.84
PARCEL 2	29299.47
PARCEL 3	3524.41
PARCEL 4	123055.62
PARCEL 5	2845.17
PARCEL 6	13282.88
PARCEL 7	45739.82
PARCEL 8	31766.86
PARCEL 9	53684.37
PARCEL 10	242183.89
PARCEL 11	6212.47
PARCEL 12	3546.59



PRELIMINARY

NUMBER	DATE	DESCRIPTION	BY

BENCHMARK ELEVATION: _____

CITY OF LATHROP
 DEPARTMENT OF PUBLIC WORKS
 390 Towne Centre Drive
 Lathrop, CA 95330
 (209) 941-7430
 (209) 941-7449 FAX

DRAWN BY: J. COMEAU
 DESIGNED BY: J. COMEAU
 CHECKED BY: R. YOSHIMURA
 SUBMITTED BY: A. SEYEDMADANI

SCALE:
 HORIZONTAL
 1"=100'
 VERTICAL

MANTHEY ROAD
BRIDGE REPLACEMENT PROJECT
RIGHT OF WAY IMPACT EXHIBIT
ALIGNMENT ALTERNATIVE 3 "GVP" LINE

DRAWING
 SHEET
 OF

T:\12588 - City of Lathrop - Manthey Road\CADD-Master\Civil\12588-ROW EXHIBIT.dwg 8-31-20 02:24:17 PM

DRAFT

ATTACHMENT G

RISK REGISTER

RISK REGISTER				Project Name:	Manthey Road Bridge Replacement Project			Project Manager	Ali Seyedmadani						
Risk Identification							Risk Assessment					Risk Response			
Status	ID #	Type	Category	Title	Risk Statement	Current status/assumptions	Probability	Cost Impact	Cost Score	Time Impact	Time Score	Response Strategy	Strategy	Risk Owner	Updated
Active	1	Threat	Design	Design Changes affecting ED	A post-approved Environmental Doc design change that is outside of the parameters contemplated in the Environmental Document triggers additional environmental which causes a delay due to the public comment period.		3-Moderate	4 -Moderate	12	8 -High	24	Progression of roadway geometric design to correlate with technical studies. Establish roadway footprint to avoid changes during subsequent phases of the project and thus avoiding reassessment of ED	Avoid	Agency	It has been minimized
Active	2	Threat	Design	Agency Review/ approval	Coordination and review of deliverables (data, reports, technical studies, etc) not completed on time.		3-Moderate	4 -Moderate	12	8 -High	24	Engage Caltrans and Resource Agencies to gain early buy-in and allow adequate time for review and approval	Mitigate	Agency & Design Team	Was partially mitigated. There was schedule impact
Retired	3	Threat	Design	Alternative development	Design changes to alignment, profile, typical cross section, and stage construction after recommended alternative is determined.		2-Low	2 -Low	4	4 -Moderate	8	Coordinate with design disciplines and approving agencies to ensure proper vetting of alternatives	Mitigate	Agency	Complete
Active	4	Threat	Design	Caltrans Approval of preferred alternative	Caltrans rejecting preferred alternative		3-Moderate	4 -Moderate	12	8 -High	24	Advance coordination with Caltrans	Mitigate	Agency	Was partially mitigated. There was schedule impact
Retired	5	Threat	Design	Bridge Design approval	Delay in US Coast Guard approval		2-Low	2 -Low	4	4 -Moderate	8	Early coordination to understand design criteria	Mitigate	Agency & Design Team	Complete
Retired	6	Threat	Design	Structure - Water Crossing	Delay in Reclamation District Approvals		2-Low	2 -Low	4	4 -Moderate	8	Early coordination to understand design criteria	Mitigate	Agency & Design Team	Complete
Retired	7	Threat	Design	Traffic Analysis/ recommendations	Delay in getting consensus over model validation to existing counts and projected development rate.		3-Moderate	2 -Low	6	4 -Moderate	12	Review with the City the SJCOG model and land use forecasts and obtain City approval prior to conducting traffic counts and project related traffic studies	Mitigate	Agency	Complete
Retired	8	Threat	Environmental	Caltrans Field Review	Caltrans approval of technical studies required and level of environmental document	Caltrans Field Review held on May 21st. Caltrans confirmed Technical Studies.	2-Low	2 -Low	4	2 -Low	4	Vetting of environmental impacts within study area prior to field review	Mitigate	Design team	Complete
Retired	9	Threat	Environmental	Timely Approval of Technical Studies	Unexpected environmental issues (archaeological, biological, etc.) discovery late in the project		3-Moderate	2 -Low	6	2 -Low	6	PM in coordination with the project environmental coordinator ensures applicable issues are documented and addressed early on the project and prior to completion of technical studies	Mitigate	Design team	Was partially mitigated. There was schedule impact
Retired	10	Threat	Environmental	Timely Spring Surveys	unable to complete 2014 Spring surveys due to weather pattern. Resource agencies (US, CA Fish and Wildlife Services) reject Spring Survey Study. Resource Agency require completion of Spring Survey in 2015		4-High	2 -Low	8	4 -Moderate	16	Early coordination with Resource Agencies to clearly understand the agencies opinion on Spring 2015	Mitigate	Design team	Complete
Retired	11	Threat	Environmental	Hazardous Waste	Discovery of hazardous waste in excavated areas		1-Very Low	2 -Low	2	2 -Low	2	A Hazardous Waste Initial Site Assessment (ISA) will be conducted during the environmental phase.	Mitigate	Agency	Complete

Retired	12	Threat	Environmental	ED Approval	Project may require an EA instead of a CE for NEPA	PES form identified NEPA ED as an EA per Caltrans Field Review discussion based on env constraints.	2-Low	2 -Low	4	8 -High	16	Early PDT decision prior to completion of environmental studies.	Mitigate	Agency	Was partially mitigated. There was schedule impact
Retired	13	Threat	Environmental	ED Approval	Extended Phase 1 is required		4-High	4 -Moderate	16	4 -Moderate	16	Begin preparation of scope for City/Caltrans review	Mitigate	Agency	Was partially mitigated. There was schedule impact
Retired	14	Threat	Environmental	ED Approval	Perform Extended Phase 1		4-High	4 -Moderate	16	4 -Moderate	16	Prepare Finding of Effect and Memorandum of Agreement	Mitigate	Agency	Was partially mitigated. There was schedule impact
Active	14	Threat	Environmental	Post Review Discovery Plan	Perform Post Review Discovery Plan (PRDP) - Requirements could impact project schedule and budget, depending on findings.		4-High	4 -Moderate	16	4 -Moderate	16	PRDP requirements will be included in the construction documents	Mitigate	Agency	Was partially mitigated. There was schedule impact
Retired	15	Threat	ROW	Project Access	Obtaining right of entry to access project area to complete field work	Received 13 of the 15 requested PTEs. Scheduled Property owner visit for 241-020-29 and 35	2-Low	2 -Low	4	4 -Moderate	8	Identify all affected properties and coordinate with the City to ensure request for entry has been submitted ontime.	Mitigate	Agency	Complete
Retired	16	Threat	ROW	Project Access	APN 241-020-68 will not allow access to perform Extended Phase 1	Prior discussion with owner will not allow any excavation on property.	4-High	4 -Moderate	16	8 -High	32	Will require an Memorandum of Agreement once right of way is acquired	Mitigate	Agency	Complete
Active	17	Threat	PM	Stakeholder	Public in disagreement with the proposed project because of lack of public awareness about the project purpose and need and inadequate response to concerns of stakeholders.		2-Low	2 -Low	4	4 -Moderate	8	Clear and transparent communication (public meeting, project website updates)	Mitigate	Agency	complete for PA&ED phase